



Slot Diffusers

Kappa 05



At Gerhman we are driven by a strong desire to continuously generate improvements. We do that by developing products and systems that are easy to use and energy efficient, together with industry-leading knowledge, support, logistics and efficient availability.



gerhman.com

Slot Diffusers



Kappa 05

The Kappa 05 linear slot diffuser is designed to meet architectural needs for continuous lengths without sacrificing air distribution performance. These diffusers feature fully adjustable aerodynamic pattern controllers made from engineered ABS nozzles and are available in a wide variety of frame styles. The Kappa 05 combines engineering excellence with architectural elegance.

Typical Applications

Aerodynamically designed blades provide a tight horizontal pattern that maintains stability even at low airflow rates. Excellent for architectural applications, the Kappa has many mounting styles and is available with multiple slot widths and quantities to meet a range of airflow requirements.

Technical Size

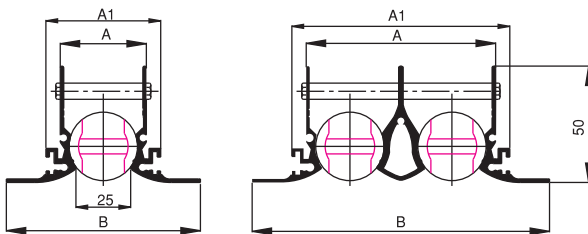

	A(mm)	A1(mm)	B(mm)
1 Slot	40	60	85
2 Slot	80	100	130
3 Slot	120	140	175
4 Slot	160	180	220

Slot Diffusers

Kappa 05

Quick Selection

Number of slot	Recommended air volume	Sound level	Pressure drop
1 slot	200 m ³ /h	<30 db	20 Pa
2 slot	400 m ³ /h	<30 db	20 Pa
3 slot	600 m ³ /h	<30 db	20 Pa
4 slot	800 m ³ /h	<30 db	20 Pa

Note: All data is given for a 1 m slot length and vertical throw.

Types

A- Both sided end caps

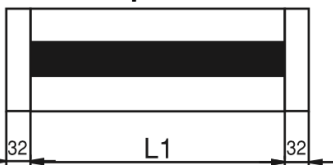

B- Without end caps

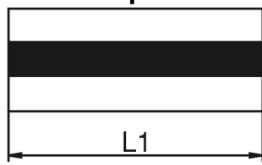

R- Left sided end cap

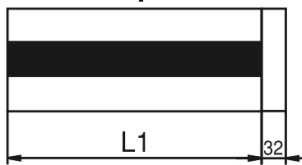

L- Right sided end cap

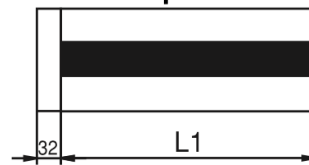

Note: Requests about side cap must be given with order.

K90-90° Corner Slot

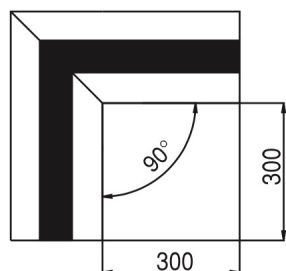

K135-135° Corner Slot

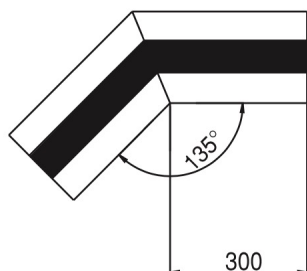

Plenum Box

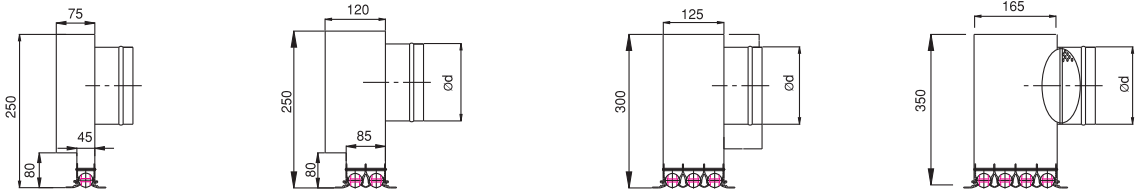

L1(mm)	400-1000			1100-1500			1600-2000			400-2000		
	ØD						h	C _K	C _A			
1 Slot	98x1	98x2	123x2	250	55	43						
2 Slot	136x1	123x2	136x2	250	95	83						
3 Slot	156x1	136x2	156x2	300	135	123						
4 Slot	198x1	156x2	198x2	350	175	163						

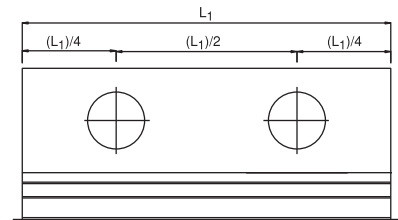

Plenum Boxes

Supplied unlined as standard with side entry spigot.

Plenum boxes can be supplied internally lined with 6mm class "O" foam at extra cost. Apply to sales office for price.

BOX INSULATION

Acoustic Insulation

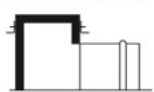

Thermal Insulation

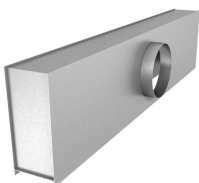
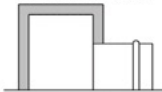

Specifications

Material

Standard is a nominal 0.7mm thick galvanised or zinc coated steel.

Construction

Plenum boxes are generally fabricated in 3 sections having tray ends, which are either mechanically joined or spot welded to form an airtight seal. Flush ends (no tray indents) are also available. As standard, spigots are side entry and located centrally. All boxes are supplied with plain edges, as standard, (F0 fixing).

Standard Installation Method

The tray ends of the plenum box incorporate a 15mm indent, on each side to allow for 8mm drop rod fixings, which gives space for holes to be drilled (by others) without disturbing the active section.

Installation Options

Fixing lugs can be factory fitted if

preferred or special fixing methods (by others) may be used.

For plenum boxes having flush ends separate hanging brackets/fixing lugs need to be fitted to allow independent support of diffuser and plenum box.

Accessories

Joggled style plenum boxes or pan adapters.

Spigot dampers include cord operated and manual quadrant.

6mm thick acoustic lining Class 'O' fire rating (Standard).

Equalising grids (50% free area perforated mesh).

Fixing lugs or special fixings (by others).

Flush ends or indented ends.

Finish

Self finish galvanised or zinc coated steel as standard.

Optional specialists finishes available.

Throw Technical Data

Horizontal Variable Air Throw

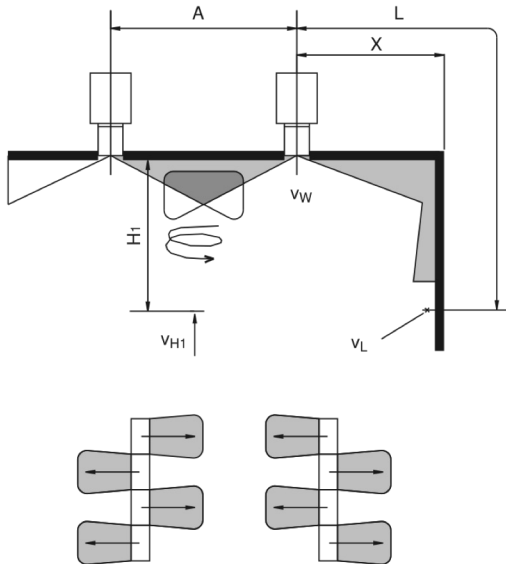

1)

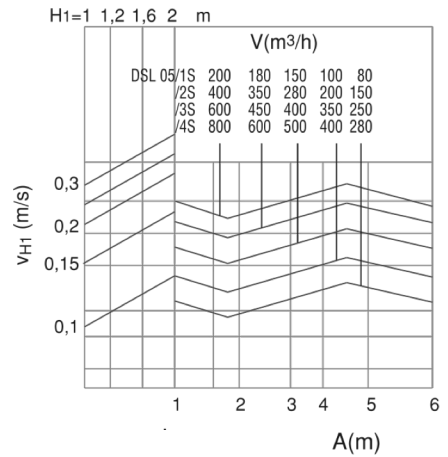

Horizontal One-Way or Two-Way Air Throw

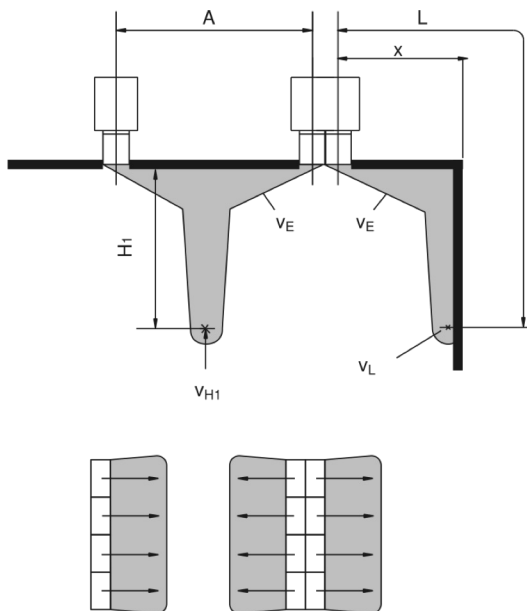

2)

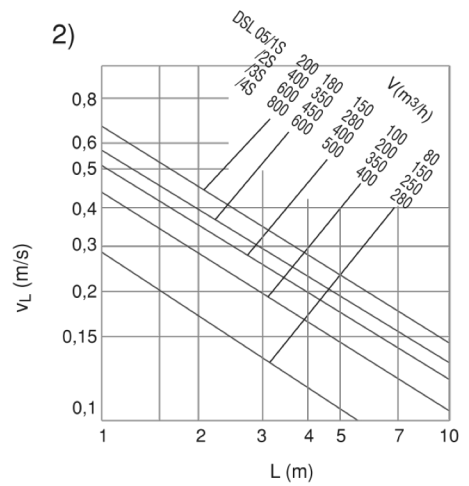

3)

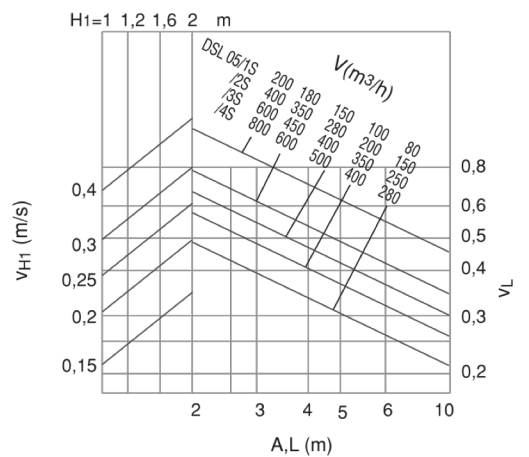

Sound Level and Pressure Drop

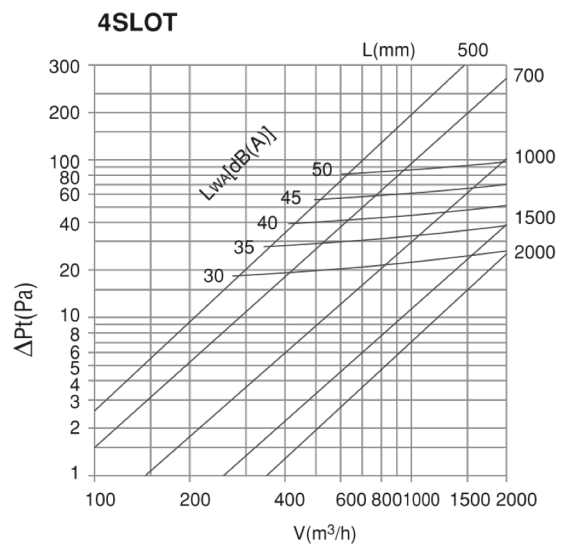
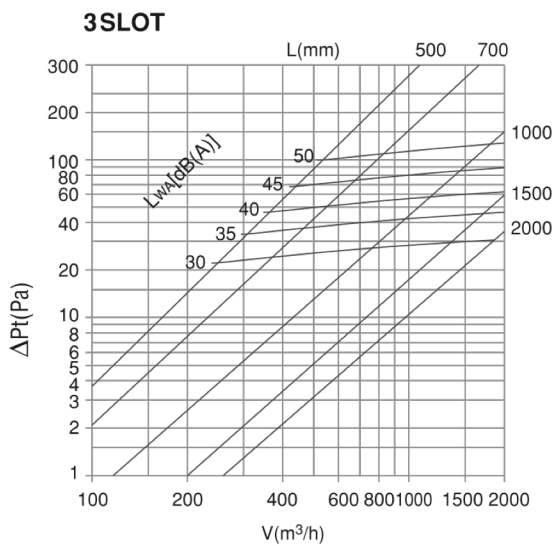
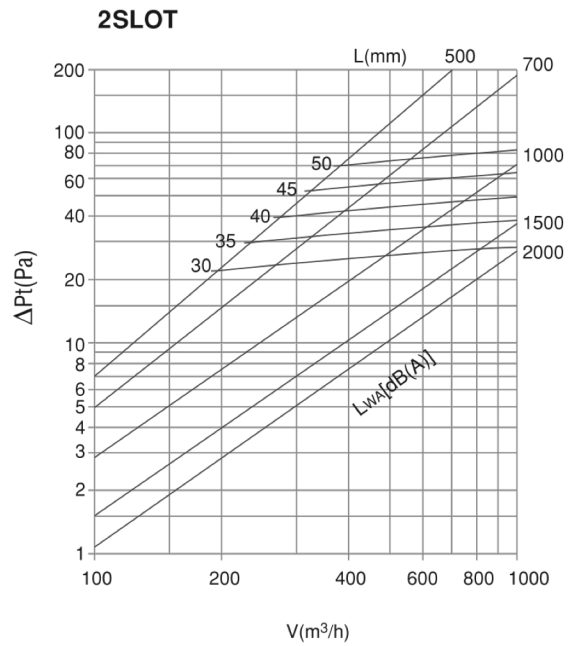
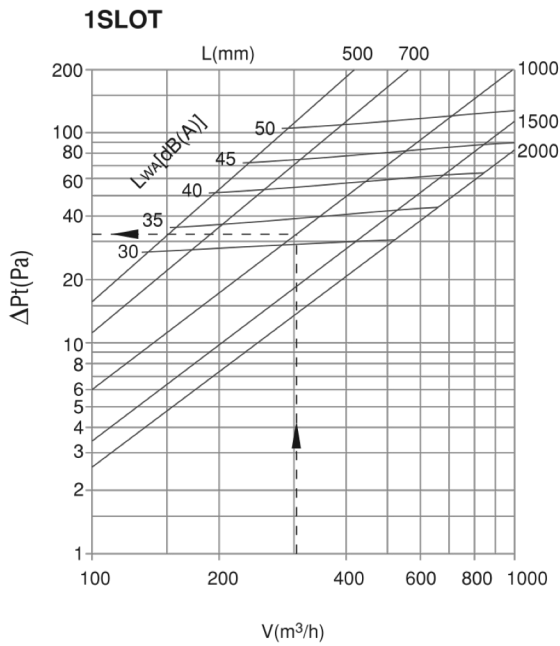

Selection Procedure

Method Slot Diffuser

1. Establish volume flow rate per metre by dividing total air volume by the active slot length to give litres/metre.
2. Using appropriate graph place a straight edge through the volume as calculated and position to pass through required throw value with satisfactory noise and pressure readings. Select suitable slot width and number of slots where straight edge passes through slot selection line. Finally realign straight edge through volume and slot selected points and read exact throw, sound and pressure figures.
3. Readings obtained from the above using horizontal ceiling graph are based on 1 metre active slot length. (See note on graph).
4. Readings obtained from the methods above using vertical projection graph are based on isothermal conditions. For vertical throw values for temperature differential see 'Vertical Throw Multipliers for Differential Temperatures' correction table to obtain throw multiplier for varying number of slots.

Exhaust

Procedure same as supply but with the anemometer probe reversed.

Plenum box drops and sound ratings

	Spigot velocity m/s					
	1.5	2.0	2.5	3.0	3.5	4.0
Pressure drop Pa*	2	4	6	8	12	16
Sound power level N*			25	30	35	40

*approximate – dependent upon entry conditions.

Pressure drops additional to slot diffuser.

Sound power level – use higher of slot or plenum value.

Vertical throw multipliers for differential temperatures

No. of slots	Temperature differential ambient / supply (°C)						
	-15	-10	-5	0	+5	+10	+15
1	1.54	1.33	1.15	1.0	0.87	0.75	0.65
2	2.0	1.59	1.26	1.0	0.79	0.63	0.50
3	2.46	1.88	1.37	1.0	0.75	0.53	0.41
4-8	2.71	1.95	1.4	1.0	0.71	0.51	0.37

Plenum box spigot volumes (l/s)

Diameter mm	Spigot velocity m/s					
	1.5	2.0	2.5	3.0	3.5	4.0
100	10	15	19	22	26	30
125	18	24	30	35	41	47
150	25	34	42	51	60	68
175	35	46	58	70	82	94
200	45	60	75	91	109	121
225	58	77	96	117	137	151
250	71	95	120	142	170	191
275	86	115	145	172	205	230
300	103	139	172	208	240	275
325	120	160	200	240	280	320
350	140	188	235	280	328	375
400	185	245	310	370	430	495

Method Plenum Boxes

1. Determined volume of plenum box by multiply chosen length of box x volume/metre of slot. (A maximum box size of 2.0m long is recommended). Plenum boxes in excess of 1500mm long require 2 or more inlet spigots.
2. Select plenum spigot size from table. Maximum entry velocity of 3.5 m/sec is recommended. Velocities in excess of this may lead to noise generation.
3. From table of 'Plenum Box Pressure Drops and Sound Ratings' read off additional pressure drop to be added to slot diffuser pressure drop from graph. Ensure that plenum box sound power level is not more than slot diffuser reading if latter is design criteria.
4. Where it is not possible to accommodate standard plenum boxes, special configurations are available, but should always maintain an equivalent cross-sectional area to a standard box. Consideration should also be given to the inlet spigot in respect of positioning, sizing and inlet velocities. Consult our technical department for detailed advice



Slot Diffusers

Kappa 05



• +90 216 606 54 44



• info@gerhman.com



• gerhman.com