



Jet Diffusers

Lynx

At Gerhman we are driven by a strong desire to continuously generate improvements. We do that by developing products and systems that are easy to use and energy efficient, together with industry-leading knowledge, support, logistics and efficient availability.



gerhman.com

Jet Diffusers

Lynx



Lynx architectural linear jet diffusers is designed to satisfy architectural applications that require continuous lengths without compromising long throw air distribution performance. These linear jet diffusers feature fully adjustable, aerodynamic pattern controllers fabricated from extruded aluminum, and are available in a large selection of frame styles. Lynx provides the ideal combination of engineering excellence and architectural appeal.

Typical Applications

They can be mounted on the wall to diffuse the air horizontally in large spaces, or the ceiling to diffuse the air downward, for instance to cover high windowed walls.

Ideal for

- Shopping centers
- Airports
- Stations
- Sport halls
- Large spaces

Design

- Supply angle of $\pm 30^\circ$
- Installation on wall to diffuse the air horizontally
- Installation on ceiling to diffuse the air downward
- Operate with a temperature differential of up to up to 12°C

Single Jet

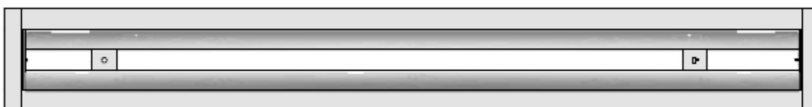

Multi Jet

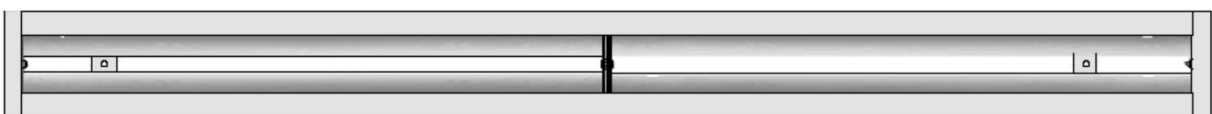

Sizes

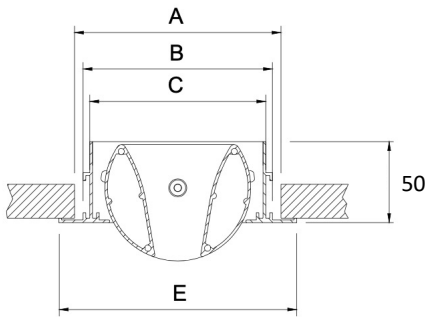

Type	A (mm)	B (mm)	C (mm)	E (mm)
15	60	50	48	105
20	65	55	53	110
25	70	60	58	115
30	75	65	63	120
40	85	75	73	130
50	95	85	83	140

Length (L): From 300 to 2000mm
 Maximum length of nozzle: 1000 mm

A= opening size
 B= neck size
 E= frame size

Performance

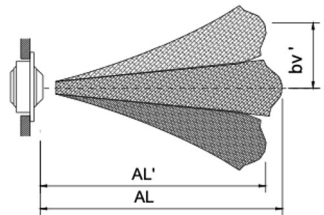

Recommended velocity

Type	V _f min m/s	V _f max m/s
15	2,5	14
20	2,5	14
25	2,5	12
30	2,5	12

Free face area (m²) for L=1000 mm

LxH	A _{free} (m ²)	Q _{min} (m ³ /h)	Q _{max} (m ³ /h)
15	0,0145	130	730
20	0,0194	175	977
25	0,0242	220	1045
30	0,0291	260	1250

FREE VELOCITY, PRESSURE LOSS AND SOUND POWER LEVEL, THROW

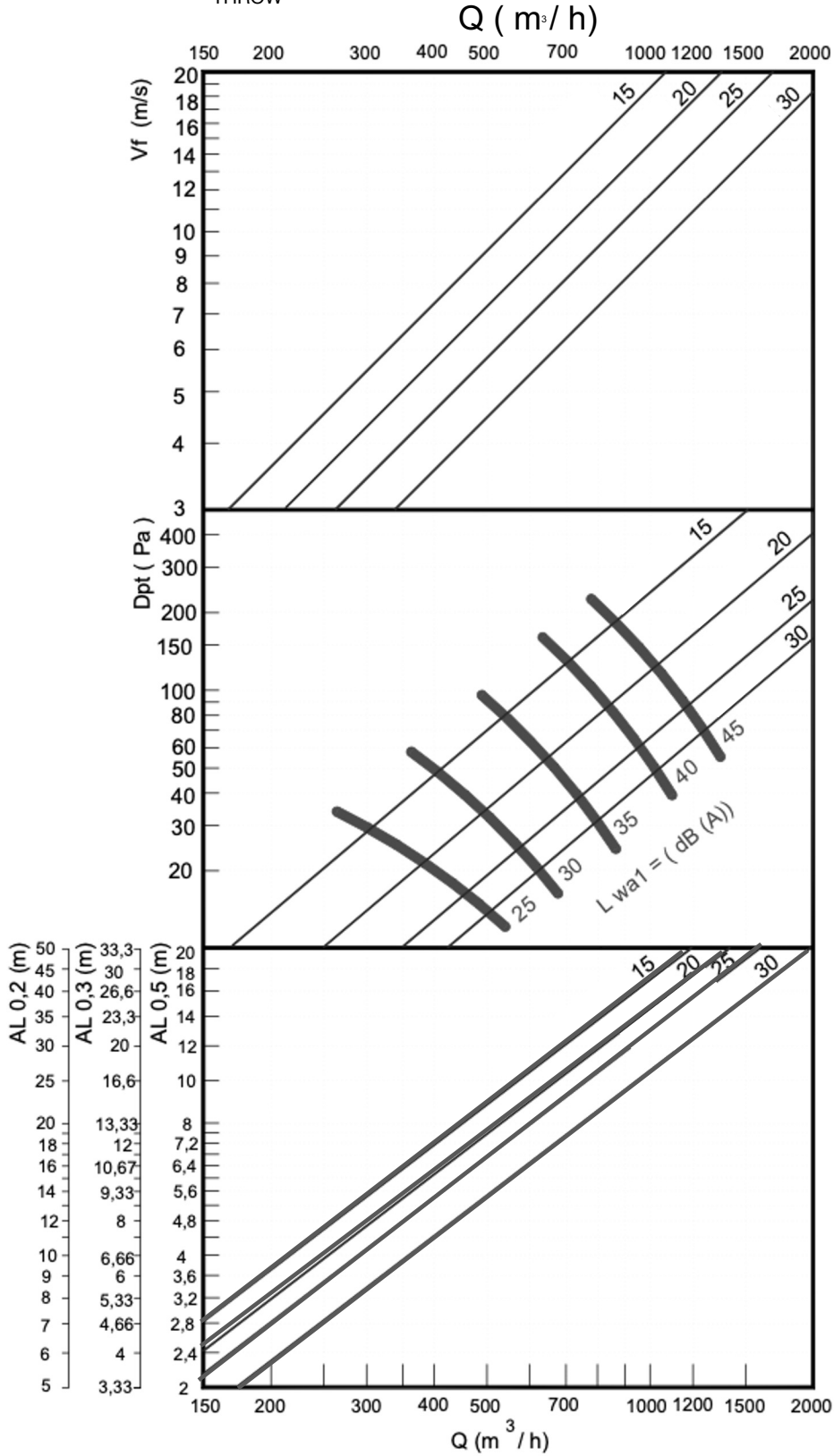

Coanda effect
 K_I 1,33

$AL' = K_I \times AL$

Recommended velocity

Type	V _f min m/s	V _f max m/s
40	2,5	10
50	2,5	10

Free face area (m²) for L=1000 mm

LxH	A _{free} (m ²)	Q _{min} (m ³ /h)	Q _{max} (m ³ /h)
40	0,0388	350	1400
50	0,0485	440	1750



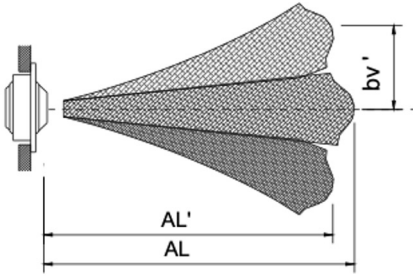

FREE VELOCITY, PRESSURE LOSS AND SOUND POWER LEVEL, THROW

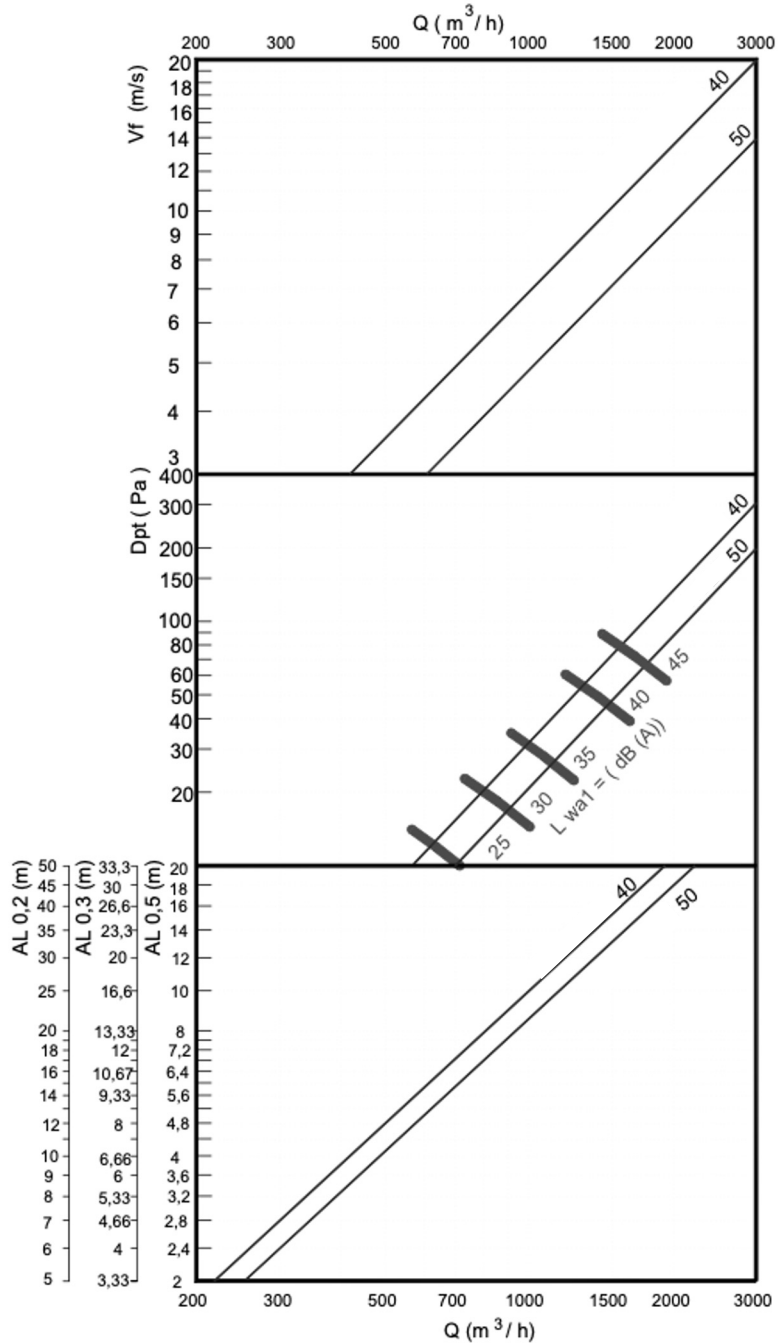

Coanda effect

$$K_1 = 1,33$$

$$AL' = K_1 \times AL$$

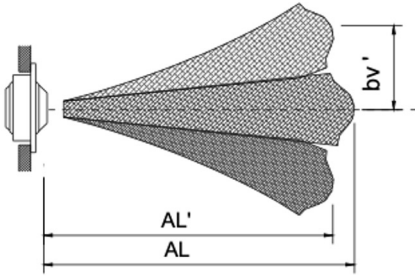

Z1	Z2
Type 15	Type 40
Type 20	Type 50
Type 25	

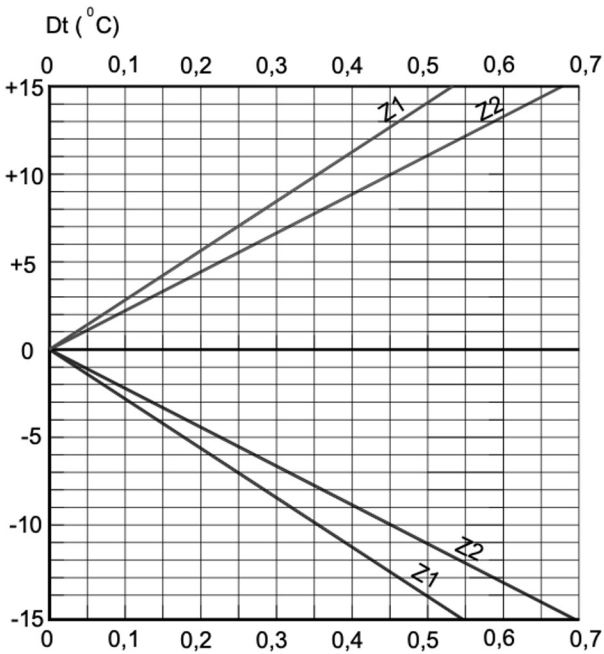

CORRECTION FACTOR FOR VERTICAL DIFFUSION (bv) FOR DT (-).

$$bv' = Kv \times AL$$

Kv = Correction factor for the vertical diffusion.

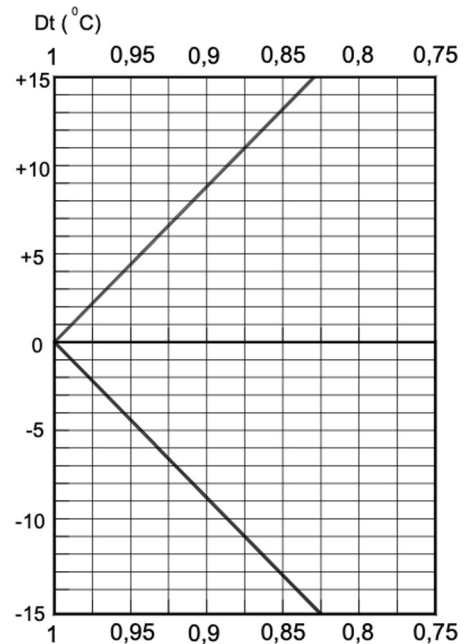

CORRECTION FACTOR FOR THROW ($L0.2$) DT (-).

$$AL' = Kl \times AL$$

Kl = Correction factor for the throw.

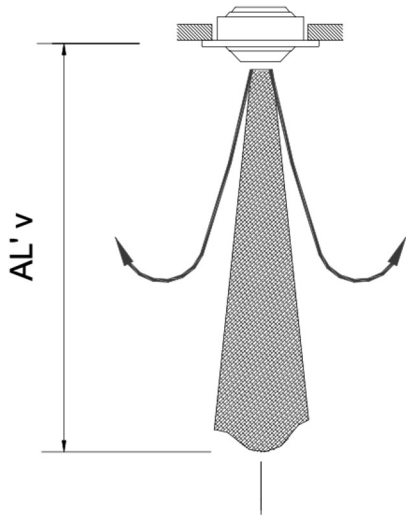

FREE VELOCITY, PRESSURE LOSS AND SOUND POWER LEVEL, THROW

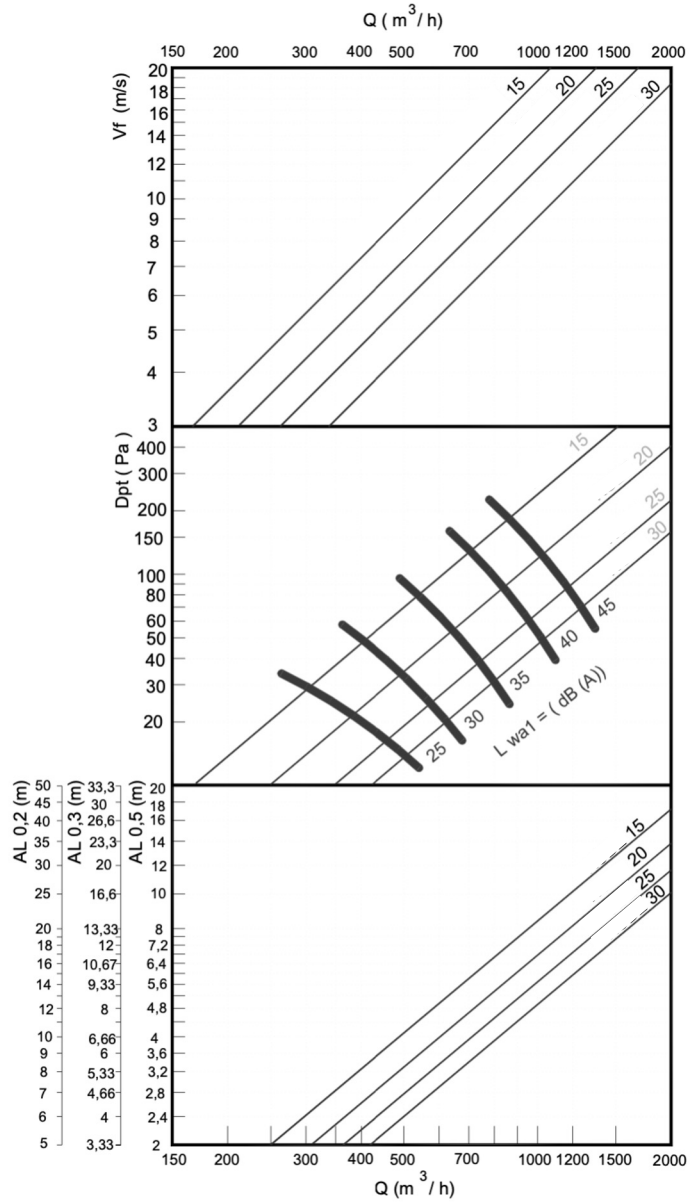

Recommended velocity

Type	V_{fmin} m/s	V_{fmax} m/s
15	2,5	9,5
20	2,5	8,5
25	2,5	8
30	2,5	8

Free face area (m²) for L=1000 mm

LxH	A _{free} (m ²)	Q _{min} (m ³ /h)	Q _{max} (m ³ /h)
15	0,0145	130	500
20	0,0194	175	600
25	0,0242	220	700
30	0,0291	260	840

Coanda effect

K_i 1,33

$AL' = K_i \times AL$

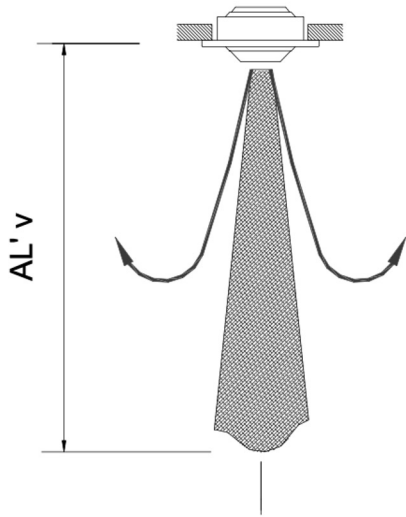

Recommended velocity

Type	Vfmin m/s	Vfmax m/s
40	2,5	8,5
50	2,5	8,5

Free face area (m²) for L=1000 mm

LxH	Afree (m ²)	Qmin (m ³ /h)	Qmax (m ³ /h)
40	0,0388	350	1200
50	0,0485	440	1480

FREE VELOCITY, PRESSURE LOSS AND SOUND POWER LEVEL, THROW

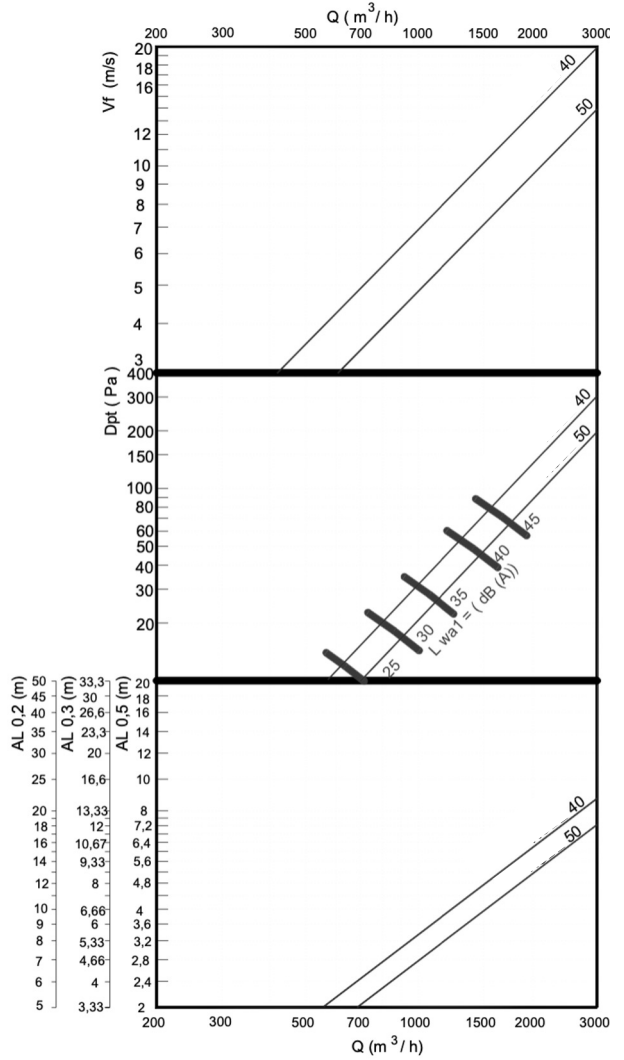

Coanda effect

K_i 1,33

$AL' = K_i \times AL$

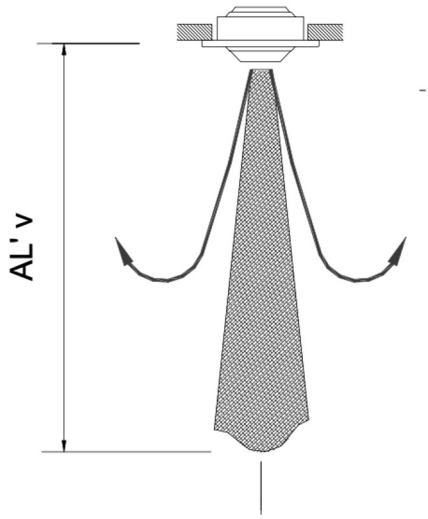

CORRECTION FACTOR FOR VERTICAL THROW ($AL'v$) DT

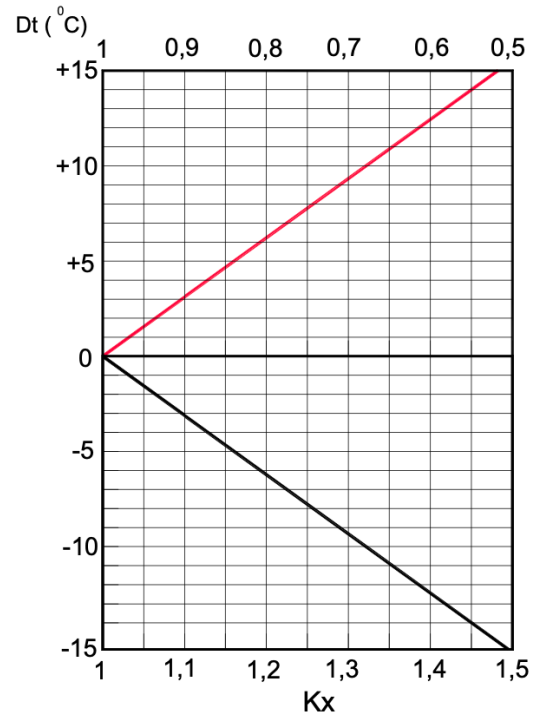

$$AL' = Kx \times AL$$

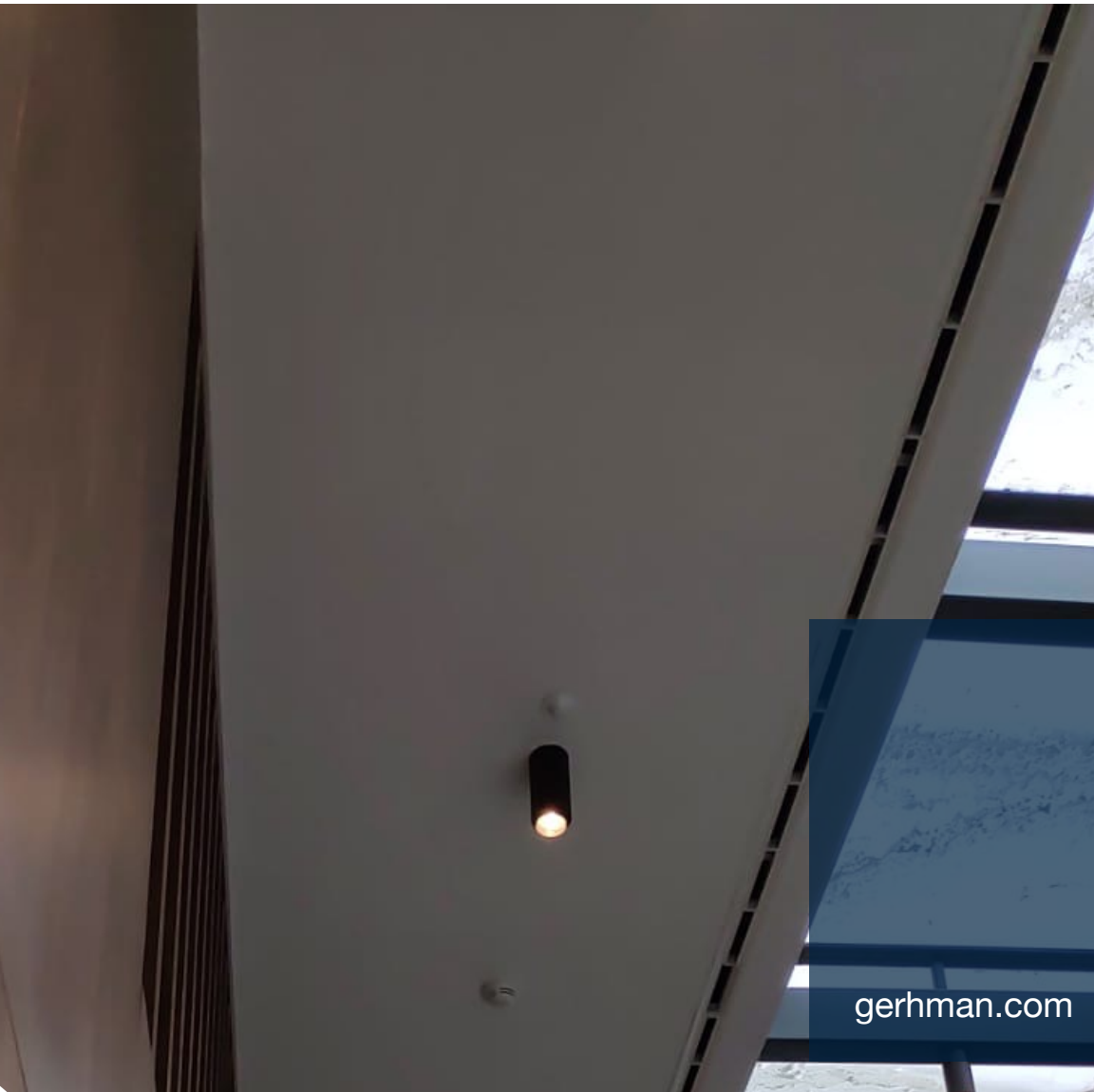

Jet Diffusers

Lynx



• +90 0216 606 54 44



• info@gerhman.com



• gerhman.com