



Slot Diffusers

Kappa

At Gerhman we are driven by a strong desire to continuously generate improvements. We do that by developing products and systems that are easy to use and energy efficient, together with industry-leading knowledge, support, logistics and efficient availability.



gerhman.com

Slot Diffusers

Kappa



The Kappa linear slot diffuser is designed to satisfy architectural applications that require continuous lengths without compromising air distribution performance. These linear slot diffusers feature fully adjustable, aerodynamic pattern controllers fabricated from extruded aluminum, and are available in a large selection of frame styles. The Kappa provides the ideal combination of engineering excellence and architectural appeal.

Typical Applications

Aerodynamically designed blades provide a tight horizontal pattern that maintains stability even at low airflow rates. Excellent for architectural applications, the Kappa has many mounting styles and is available with multiple slot widths and quantities to meet a range of airflow requirements.

•Models

- Supply (Kappa-S)
- Return (Kappa-R)
- Curved supply/return (Kappa-C)

•Slot Quantity

- 1 to 10

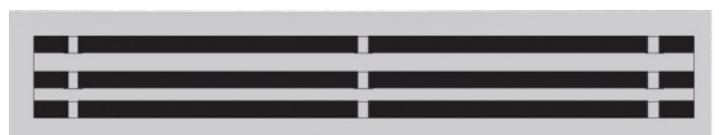

Slot Diffusers

Kappa



Quick Selection

No. of Slot		Air Volume	Sound Level	Pressure Drop	Face Velocity	Throw Distance
		m ³ /h	db A	Pa	m/s	@ 0,25 m/s
1 SLOT	Minimum	115	20<	0,4	2	2,5 mt
	Maximum	285	40	22	5	5,5 mt
2 SLOT	Minimum	230	20<	0,4	2	3,5 mt
	Maximum	600	42	23	5	8 mt
3 SLOT	Minimum	340	20<	0,4	2	4,1 mt
	Maximum	865	46	23	5	10,1 mt
4 SLOT	Minimum	465	20<	0,4	2	4,7 mt
	Maximum	1100	47	23	5	12 mt

Note: All data is given for a 1 m slot length and vertical throw.

Technical Sizes

Standard: Fixing with bridge

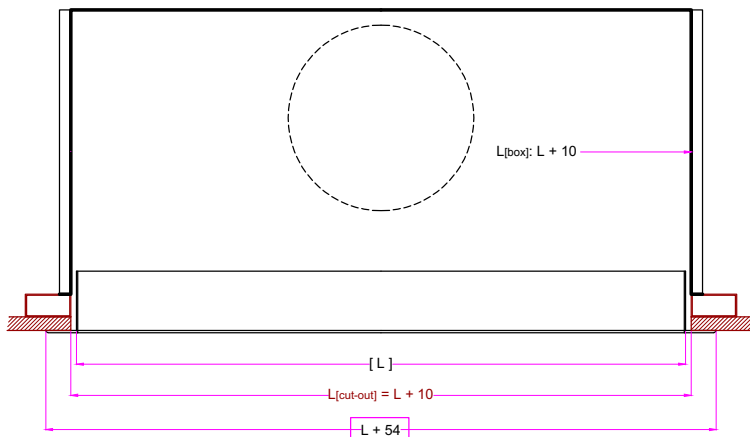
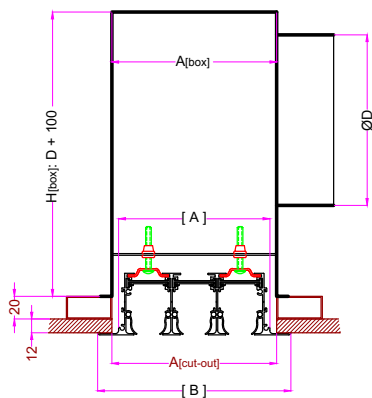

Optional: Fixing with clips

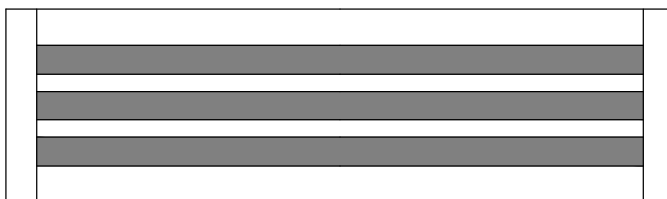
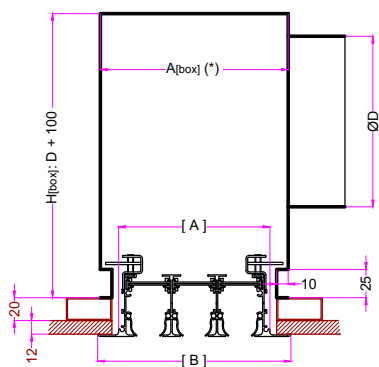

	1slot	2slot	3slot	4slot
A	60	100	140	180
B	90	130	170	210
A[box]	65	105	145	185
A[box] (*)	85	125	165	205
A[cut-out]	65	105	145	185

(*) Fixing with clips

Types

A- Both sided end caps

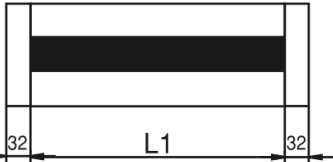

B- Without end caps

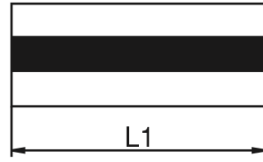

R- Left sided end cap

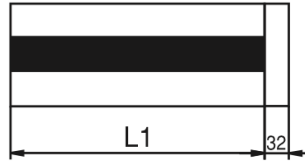

L- Right sided end cap

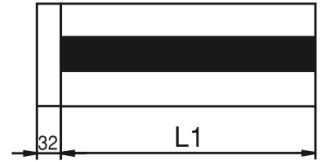

Note: Requests about side cap must be given with order.

K90-90° Corner Slot

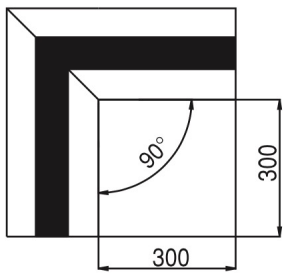

K135-135° Corner Slot

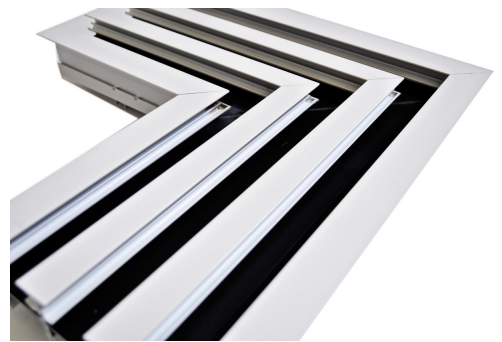
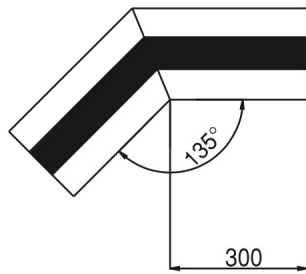

Plenum Box

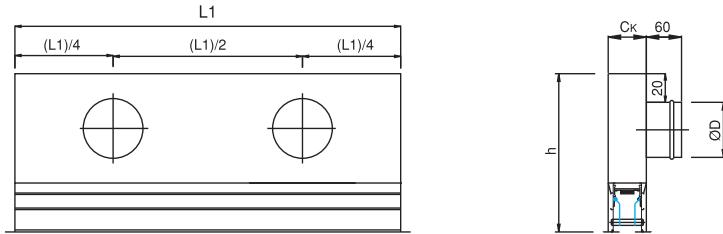
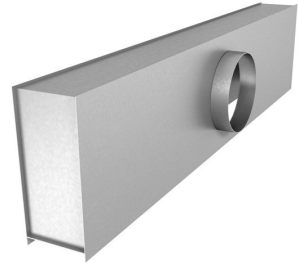

Box Heights and Neck Sizes According to Plenum Box Length

L1 (mm)	400-1000	1100-2000	400-2000	
Boğaz Sayısı	Tek	İki		
	ØD		h	Ck
1 Slot	123	123	250	65
2 Slot	148	148	250	95
3 Slot	198	198	300	125
4 Slot	248	248	300	155

Plenum Boxes

Supplied unlined as standard with side entry spigot.

Plenum boxes can be supplied internally lined with 6mm class "O" foam at extra cost. Apply to sales office for price.

BOX INSULATION

Acoustic Insulation



Thermal Insulation

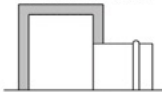

Specifications

Material

Standard is a nominal 0.7mm thick galvanised or zinc coated steel.

Construction

Plenum boxes are generally fabricated in 3 sections having tray ends, which are either mechanically joined or spot welded to form an airtight seal. Flush ends (no tray indents) are also available. As standard, spigots are side entry and located centrally. All boxes are supplied with plain edges, as standard, (F0 fixing).

Standard Installation Method

The tray ends of the plenum box incorporate a 15mm indent, on each side to allow for 8mm drop rod fixings, which gives space for holes to be drilled (by others) without disturbing the active section.

Installation Options

Fixing lugs can be factory fitted if

preferred or special fixing methods (by others) may be used.

For plenum boxes having flush ends separate hanging brackets/fixing lugs need to be fitted to allow independent support of diffuser and plenum box.

Accessories

Joggled style plenum boxes or pan adapters.

Spigot dampers include cord operated and manual quadrant.

6mm thick acoustic lining Class 'O' fire rating (Standard).

Equalising grids (50% free area perforated mesh).

Fixing lugs or special fixings (by others).

Flush ends or indented ends.

Finish

Self finish galvanised or zinc coated steel as standard.

Optional specialists finishes available.

Installation

Mounting Types

Standard mounting type is mounting with metal bridge. Slot diffuser, plenum box is mounted separately with metal bridge.

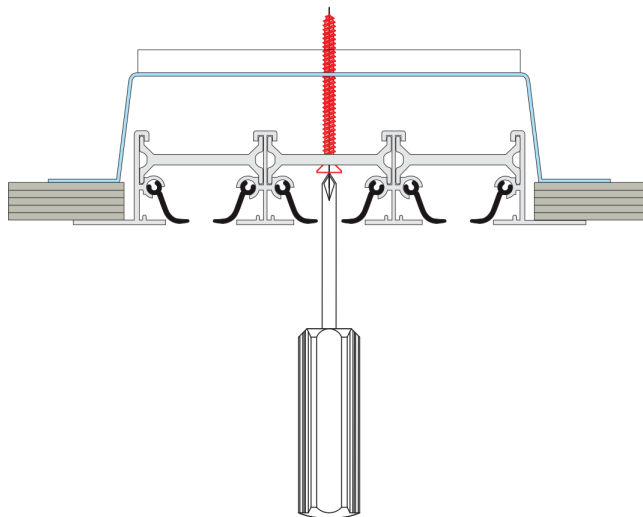

Continues mounting of slot diffusers

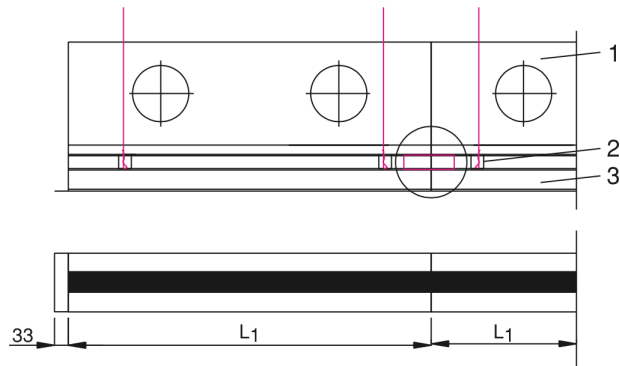

As it is shown in the figure, slot diffusers can be mounted side by side for long distances.

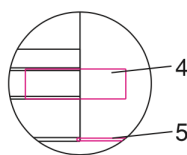

- 1-Plenum Box
- 2-Hanger
- 3-Slot Diffuser
- 4-Connection Point
- 5-Joining Pin

Air Patterns

Single direction supply

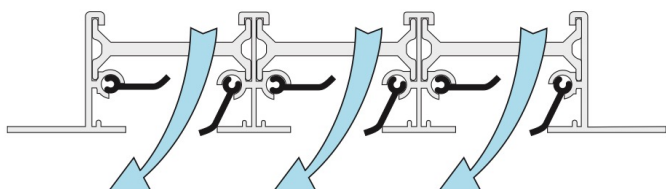

Multidirectional supply

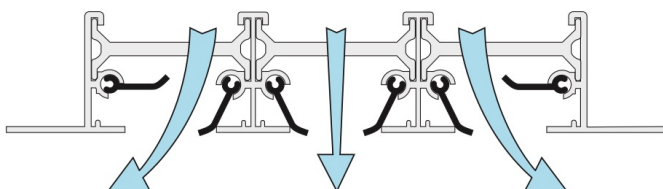

Single direction with extract

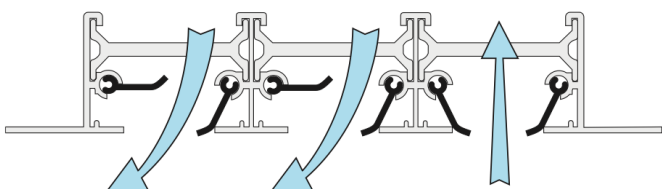

Extract

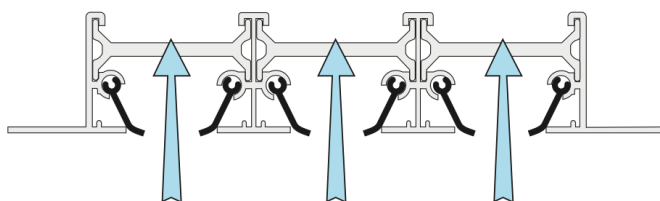

Supply with ceiling effect

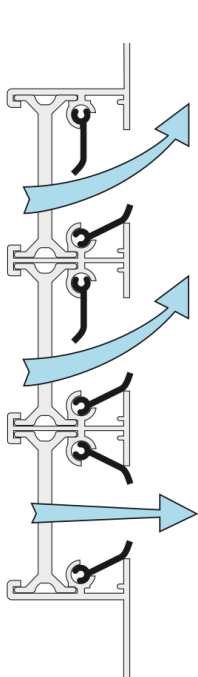

Extract

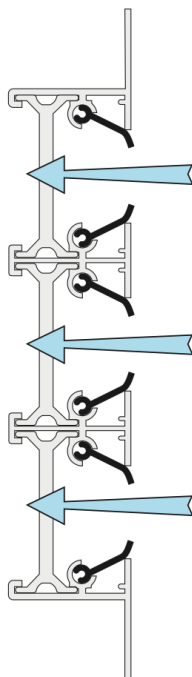

Supply free space

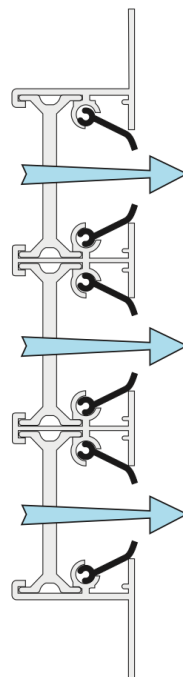

Vertical Projection

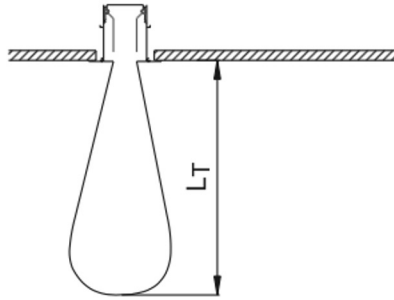
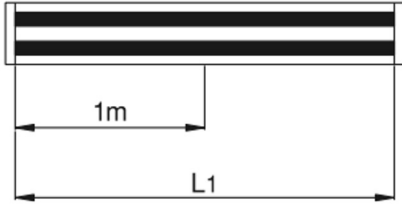

- V (m³/h) : Flow rate
- ΔPt (Pa) : Pressure loss
- V_k (m/s) : Slot outlet velocity
- A_k (m²) : Effective area
- L_t (m) : Throwing distance
- V_t (m/s) : Velocity at the target area
- NR : Sound level

All datas are given according to 1 meter length.

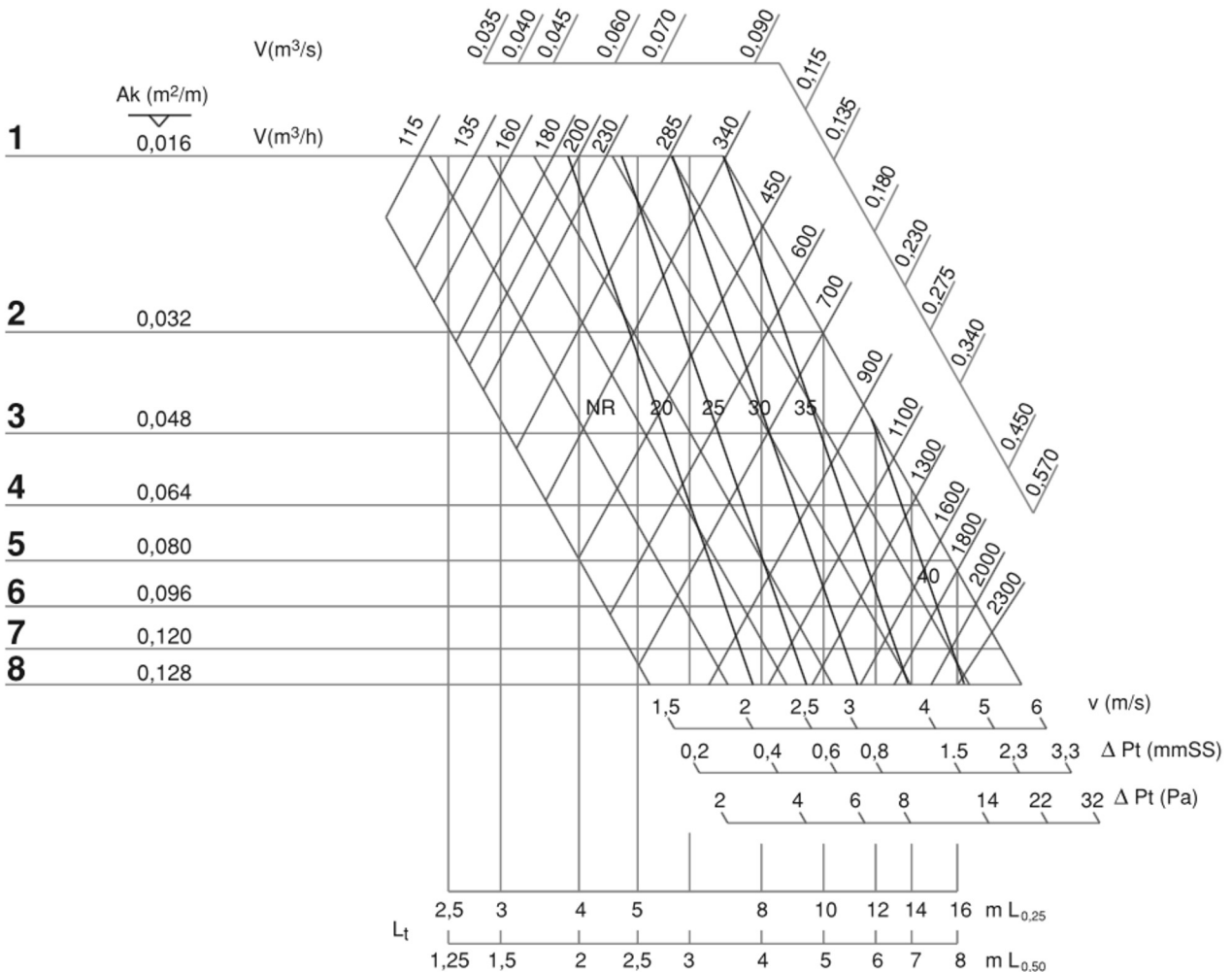

Horizontal Projection

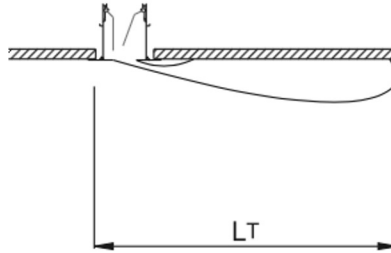
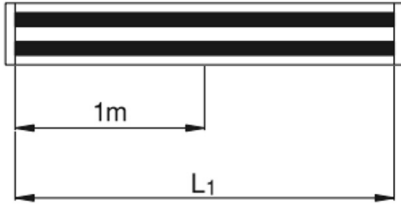

- V (m³/h) : Flow rate
- ΔPt (Pa) : Pressure loss
- V_k (m/s) : Slot outlet velocity
- A_k (m²) : Effective area
- L_t (m) : Throwing distance
- V_i (m/s) : Velocity at the target area
- NR : Sound level

All datas are given according to 1 meter length.

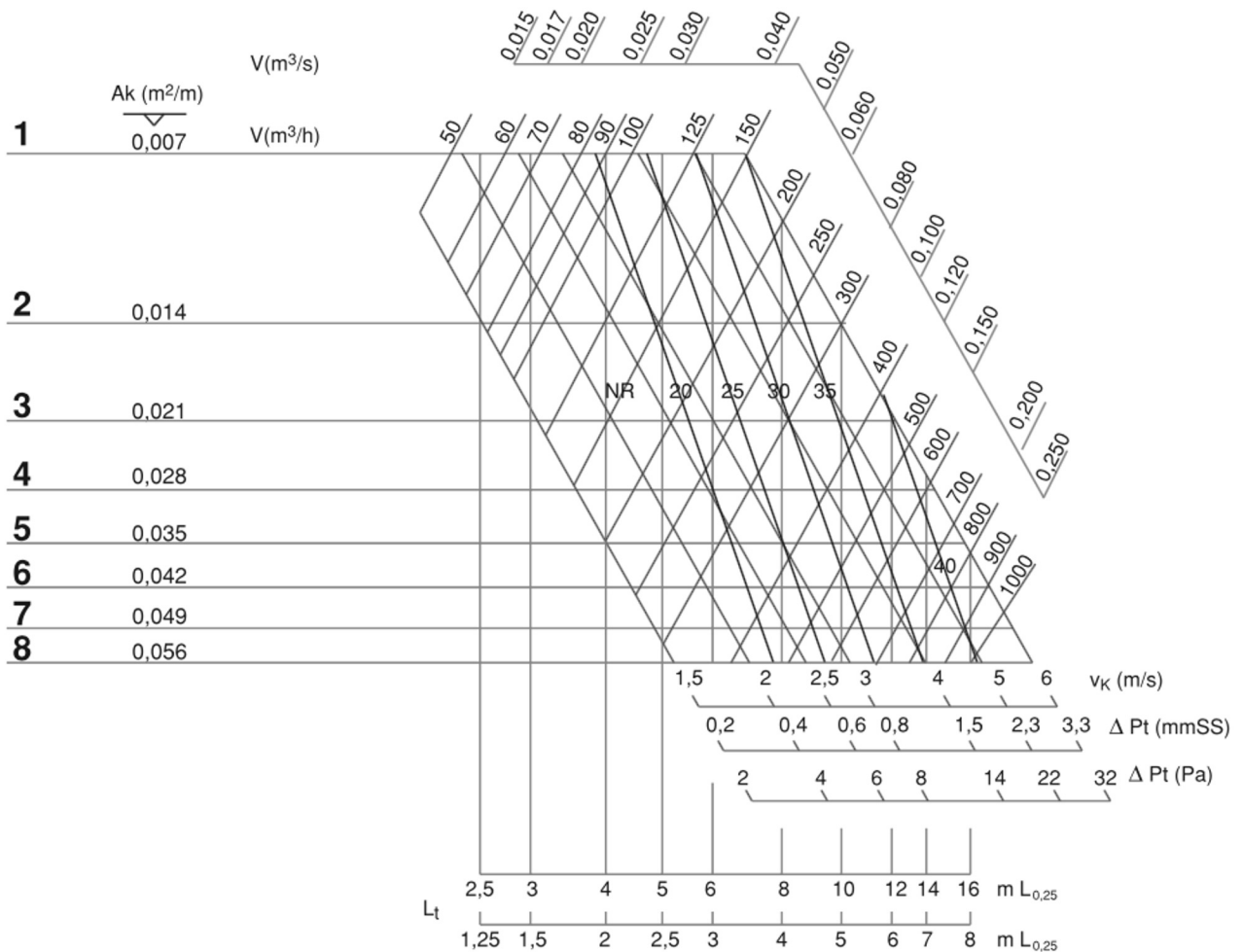

Selection Procedure

Method Slot Diffuser

1. Establish volume flow rate per metre by dividing total air volume by the active slot length to give litres/metre.

2. Using appropriate graph place a straight edge through the volume as calculated and position to pass through required throw value with satisfactory noise and pressure readings. Select suitable slot width and number of slots where straight edge passes through slot selection line. Finally realign straight edge through volume and slot selected points and read exact throw, sound and pressure figures.

3. Readings obtained from the above using horizontal ceiling graph are based on 1 metre active slot length. (See note on graph).

4. Readings obtained from the methods above using vertical projection graph are based on isothermal conditions. For vertical throw values for temperature differential see 'Vertical Throw Multipliers for Differential Temperatures' correction table to obtain throw multiplier for varying number of slots.

Exhaust

Procedure same as supply but with the anemometer probe reversed.

Plenum box drops and sound ratings

	Spigot velocity m/s					
	1.5	2.0	2.5	3.0	3.5	4.0
Pressure drop Pa*	2	4	6	8	12	16
Sound power level N*			25	30	35	40

*approximate – dependent upon entry conditions.

Pressure drops additional to slot diffuser.

Sound power level – use higher of slot or plenum value.

Vertical throw multipliers for differential temperatures

No. of slots	Temperature differential ambient / supply (°C)						
	-15	-10	-5	0	+5	+10	+15
1	1.54	1.33	1.15	1.0	0.87	0.75	0.65
2	2.0	1.59	1.26	1.0	0.79	0.63	0.50
3	2.46	1.88	1.37	1.0	0.75	0.53	0.41
4-8	2.71	1.95	1.4	1.0	0.71	0.51	0.37

Plenum box spigot volumes (l/s)

Diameter mm	Spigot velocity m/s					
	1.5	2.0	2.5	3.0	3.5	4.0
100	10	15	19	22	26	30
125	18	24	30	35	41	47
150	25	34	42	51	60	68
175	35	46	58	70	82	94
200	45	60	75	91	109	121
225	58	77	96	117	137	151
250	71	95	120	142	170	191
275	86	115	145	172	205	230
300	103	139	172	208	240	275
325	120	160	200	240	280	320
350	140	188	235	280	328	375
400	185	245	310	370	430	495

Method Plenum Boxes

1. Determined volume of plenum box by multiply chosen length of box x volume/metre of slot. (A maximum box size of 2.0m long is recommended). Plenum boxes in excess of 1500mm long require 2 or more inlet spigots.

2. Select plenum spigot size from table. Maximum entry velocity of 3.5 m/sec is recommended. Velocities in excess of this may lead to noise generation.

3. From table of 'Plenum Box Pressure Drops and Sound Ratings' read off additional pressure drop to be added to slot diffuser pressure drop from graph. Ensure that plenum box sound power level is not more than slot diffuser reading if latter is design criteria.

4. Where it is not possible to accommodate standard plenum boxes, special configurations are available, but should always maintain an equivalent cross-sectional area to a standard box. Consideration should also be given to the inlet spigot in respect of positioning, sizing and inlet velocities. Consult our technical department for detailed advice



Slot Diffusers

Kappa



• +90 0850 303 4766



• info@gerhman.com



• gerhman.com