



Architectural Diffusers

Kappa-LB Seamless Linear Bar

Slot Diffuser



At Gerhman we are driven by a strong desire to continuously generate improvements. We do that by developing products and systems that are easy to use and energy efficient, together with industry-leading knowledge, support, logistics and efficient availability.



gerhman.com



Architectural Diffusers

Kappa-LB Seamless Linear Bar

Slot Diffuser

Created for Architects and Interior Designers, our seamless slot diffusers are integrated seamlessly within the interior architecture. Installed directly into drywall or acoustical ceilings, these innovative air outlets give architects creative freedom by eliminating ugly air registers and vents. Minimal and sublime, Kappa-LB is as discreet as it gets. It blends seamlessly into any ceiling or wall for a clean, modern look that complements the surrounding architecture.

Typical Applications

Aerodynamically designed blades provide a tight horizontal pattern that maintains stability even at low airflow rates. Excellent for architectural applications, the Kappa-LB has many mounting styles and is available with multiple slot widths and quantities to meet a range of airflow requirements.

Key Features

- Frameless, flush mount installation
- Used for both SUPPLY & RETURN
- Suits gypsum, acoustical, tile, or custom system ceilings and walls
- Available in any length and slot opening
- Curved options are available
- Lower noise criteria
- Simple and swift installation

Architectural Diffusers

Kappa-LB Seamless Slot Diffuser

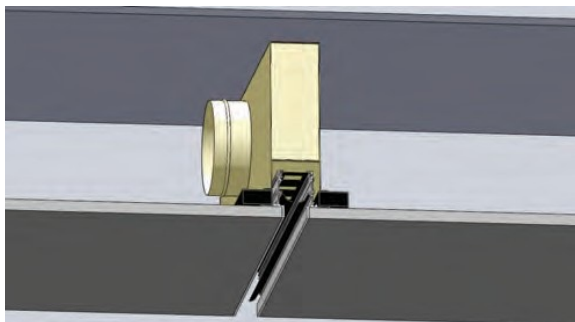

DESCRIPTION:

Kappa-LB is specially designed to suit the contemporary architectural demands of modern-day interior designers. The seamless blending of slot diffusers into the ceiling along with enhanced performance makes it a fine choice.



Application:

Kappa-LB slot diffuser is designed to be flushed with ceiling tile and serve ceiling mounted applications. No flange is visible and the view of a black opening into the ceiling gives a high-class finish to the interior. Kappa-LB can handle more air volume per length for the same opening as compared to regular slot diffuser.

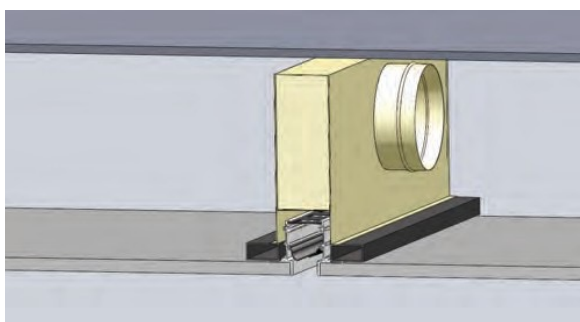

Accessories:

Kappa-LB is equipped with special side deflector to channel the airflow smoothly towards the opening without any resistance to air flow thereby reducing the pressure drop and subsequently the noise level. White frame with black interior makes the finish more attractive.

Technical Details

- Frame: High quality extruded aluminium profile.
- Deflector: Flat Aluminium profile with rounded edges.
- Powder coated frame as per RAL colour codes with black interior.
- Heating and cooling mode.
- Installed directly into drywall or ceilings.



•Models

- Supply
- Return
- Curved supply/return
- Dummy



Ideas for Architects

Quick Selection

L=1000 mm			
	Suggested Air Volume for Vertical Throw		
No of slots	m ³ /h	NR	Pa
1 slot	200	20	10
2 slot	400	20	10
3 slot	600	20	10
4 slot	700	25	10

* Included plenum performance

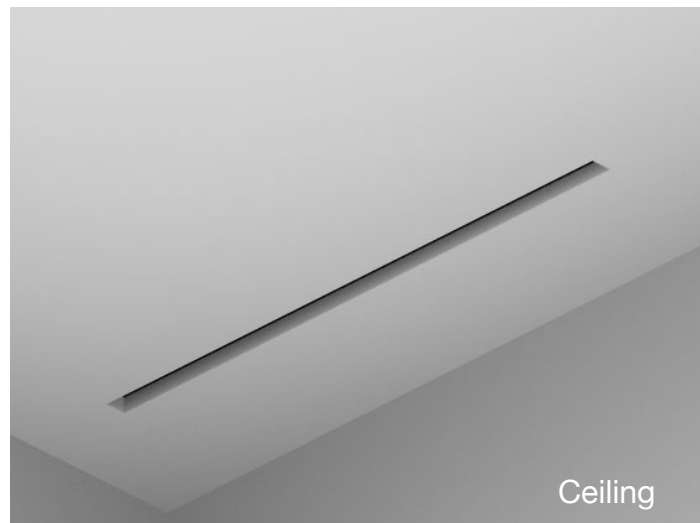
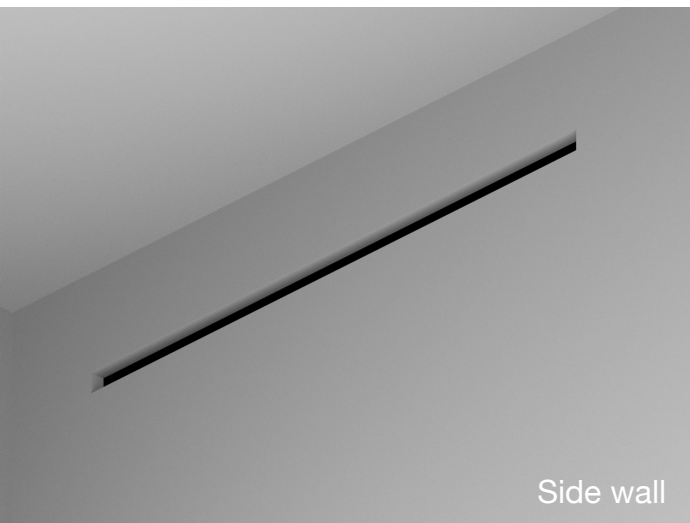

Kappa-LB



Ideas for Architects

Applications

Corners

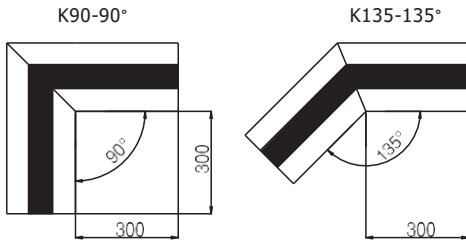

Curved

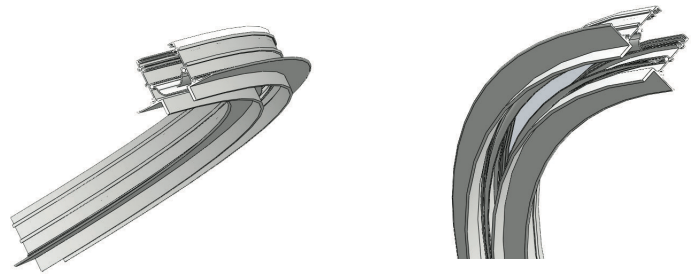

Plenum box

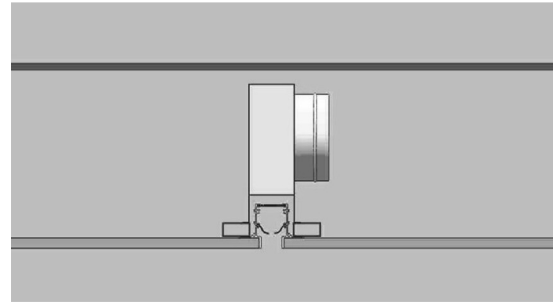
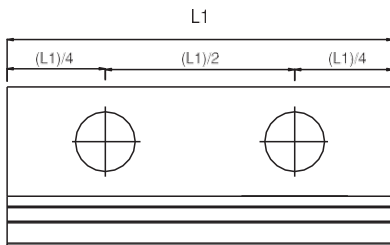

Plenum Box Height and Spigot sizes

L1 (mm)	400-1000	1100-2000	400-2000
No of spigot	Single	Double	Box height
Slot	(mm)	(mm)	(mm)
1 slot	123	123	250
2 slot	148	148	250
3 slot	198	198	300
4 slot	198	198	300

Plenum box

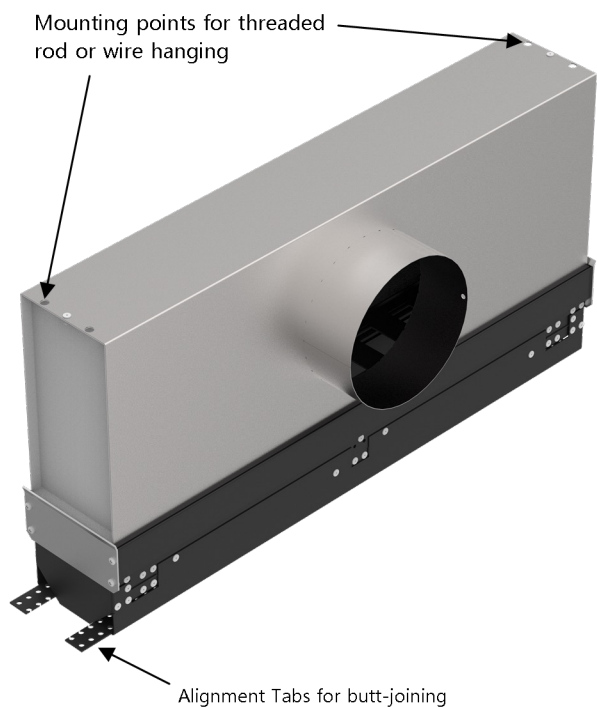
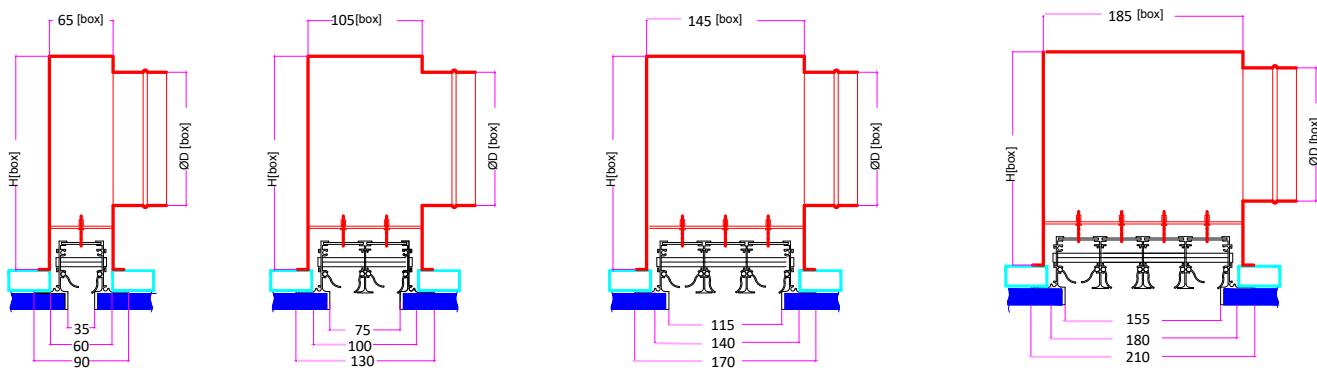
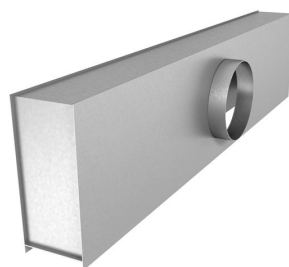

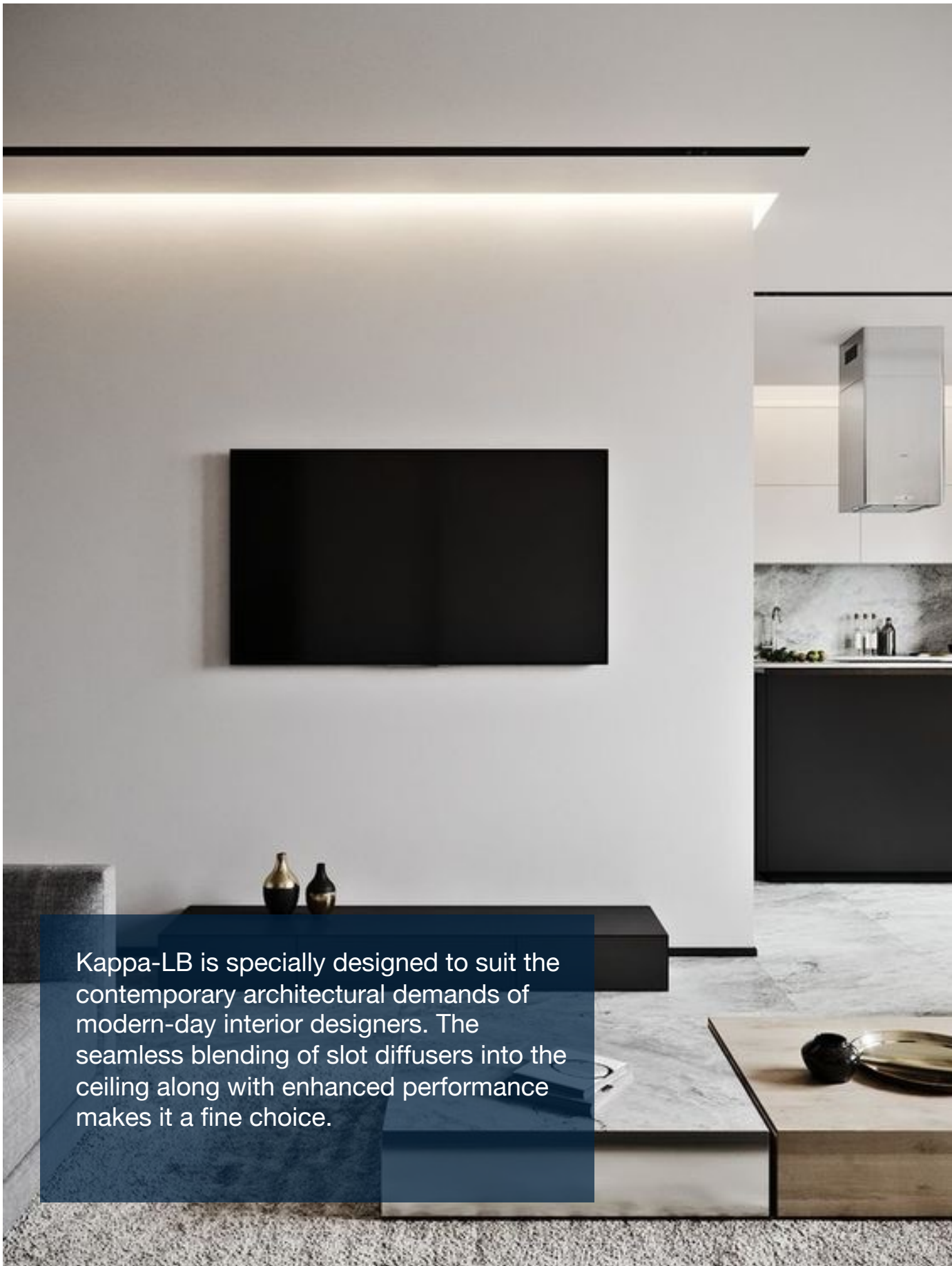

Kappa-LB is specially designed to suit the contemporary architectural demands of modern-day interior designers. The seamless blending of slot diffusers into the ceiling along with enhanced performance makes it a fine choice.

Vertical Projection

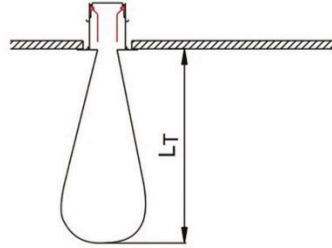
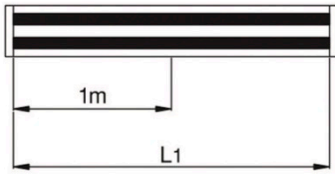

V (m³/h): Air volume
 Pt (Pa): Pressure loss
 V_k (m/s): Discharge velocity
 A_k (m²): Effective area
 L_T (m): Throw distance
 V_T (m): Velocity at comfort area
 NR: Sound Level

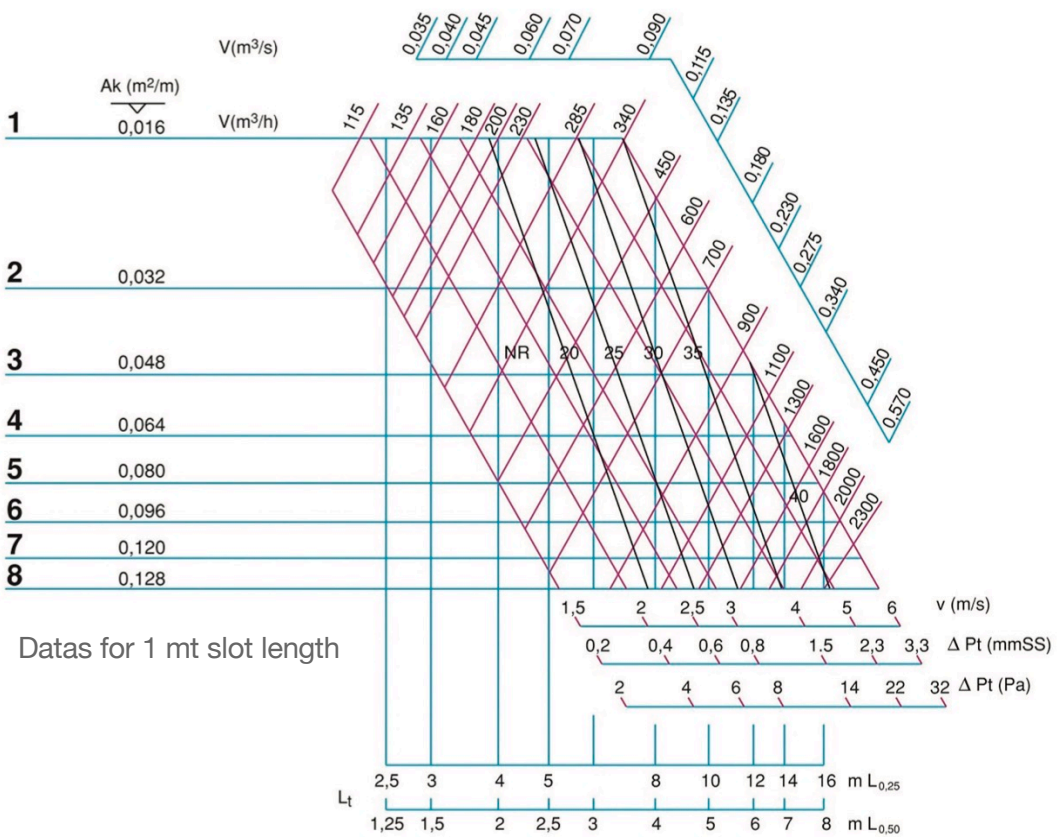

Horizontal Projection

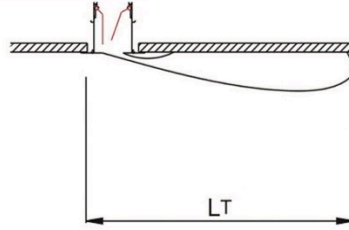
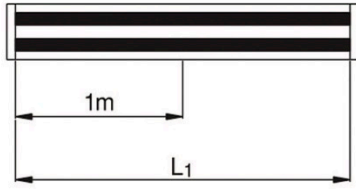

V (m³/h): Air volume
 P_t (Pa): Pressure loss
 V_k (m/s): Discharge velocity
 A_k (m²): Effective area
 LT (m): Throw distance
 V_T (m): Velocity at comfort area
 NR : Sound Level

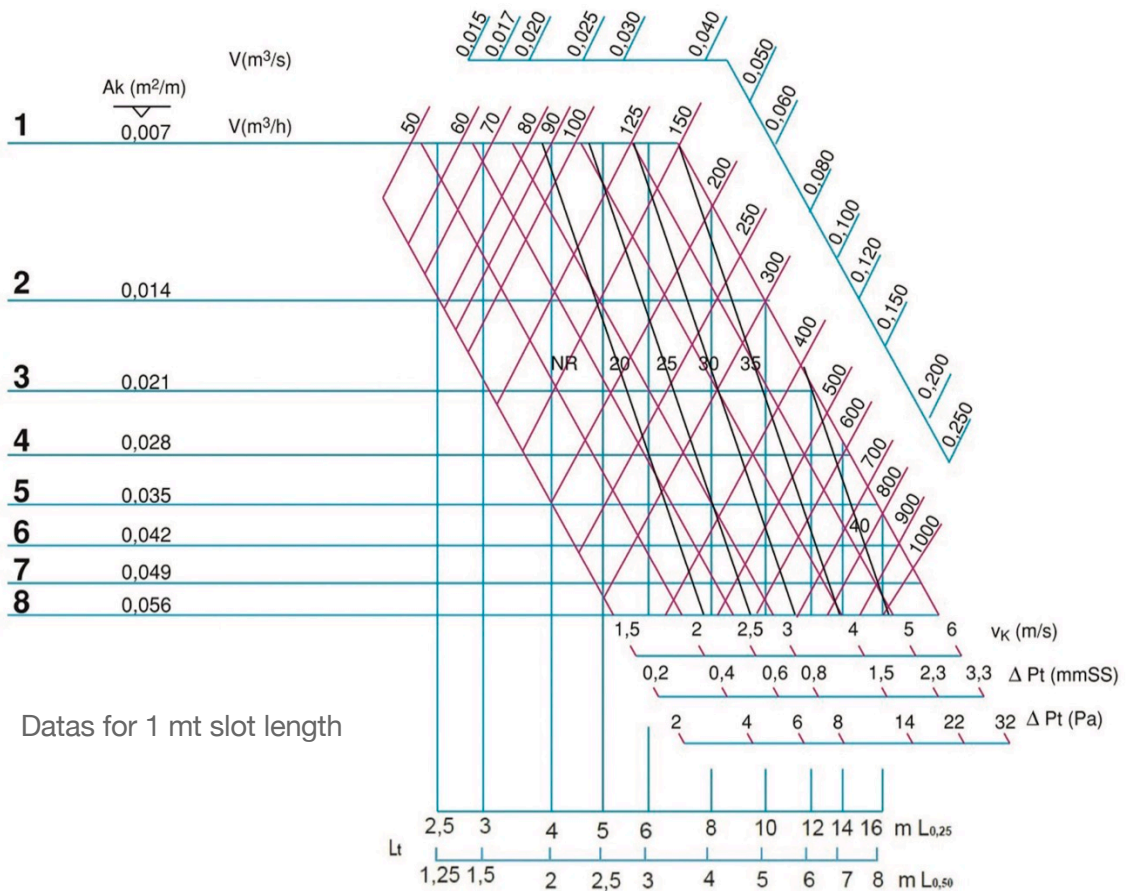

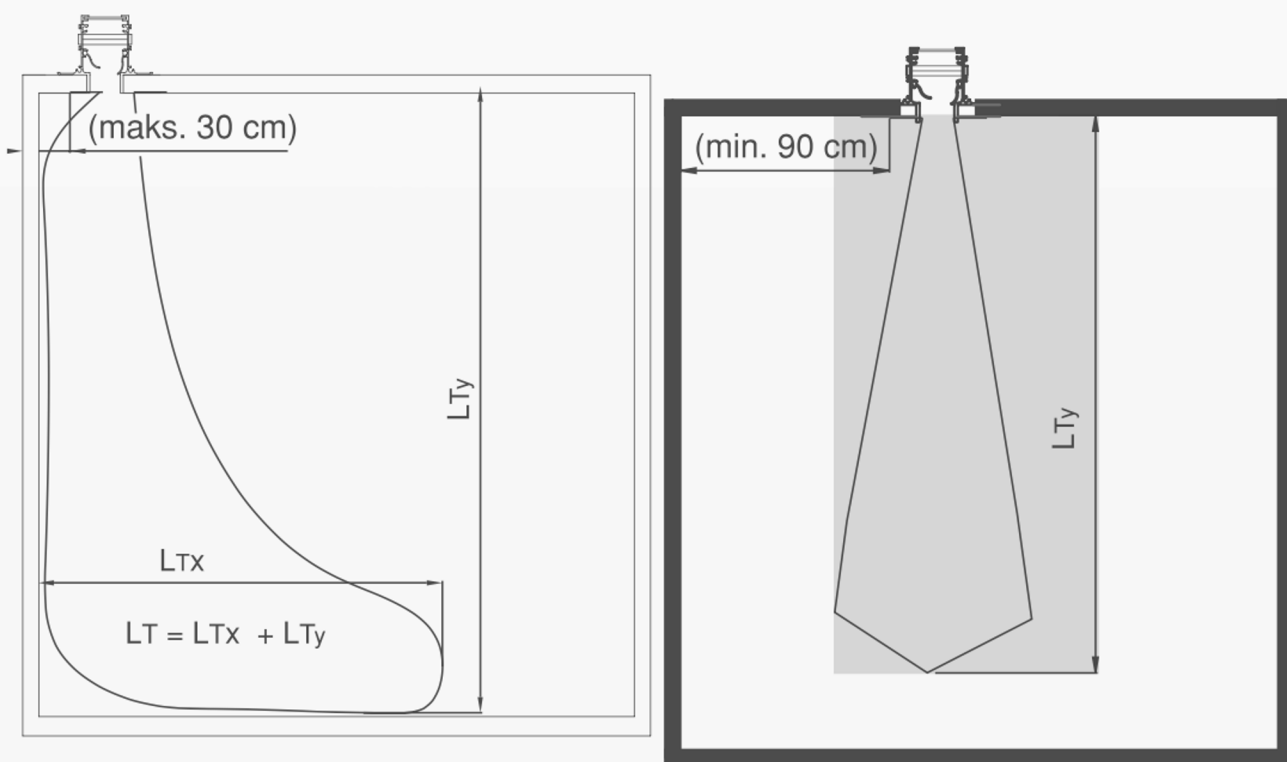

Installation

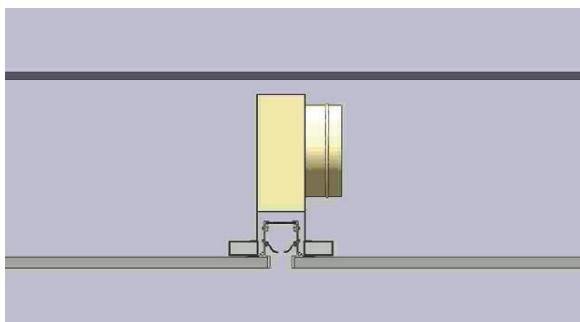

1- Bridge

Standard mounting type is mounting with metal bridge. Slot diffuser, plenum box is mounted separately with metal bridge

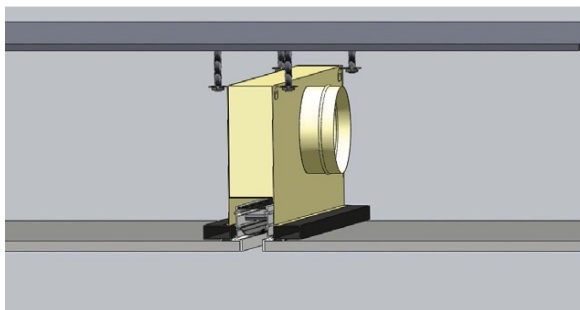

2- Hidden screw

Screwed from the frame.

Selection Procedure

Method Slot Diffuser

1. Establish volume flow rate per metre by dividing total air volume by the active slot length to give litres/metre.

2. Using appropriate graph place a straight edge through the volume as calculated and position to pass through required throw value with satisfactory noise and pressure readings. Select suitable slot width and number of slots where straight edge passes through slot selection line. Finally realign straight edge through volume and slot selected points and read exact throw, sound and pressure figures.

3. Readings obtained from the above using horizontal ceiling graph are based on 1 metre active slot length. (See note on graph).

4. Readings obtained from the methods above using vertical projection graph are based on isothermal conditions. For vertical throw values for temperature differential see 'Vertical Throw Multipliers for Differential Temperatures' correction table to obtain throw multiplier for varying number of slots.

Exhaust

Procedure same as supply but with the anemometer probe reversed.

Plenum box drops and sound ratings

	Spigot velocity m/s					
	1.5	2.0	2.5	3.0	3.5	4.0
Pressure drop Pa*	2	4	6	8	12	16
Sound power level N*			25	30	35	40

*approximate – dependent upon entry conditions.

Pressure drops additional to slot diffuser.

Sound power level – use higher of slot or plenum value.

Vertical throw multipliers for differential temperatures

No. of slots	Temperature differential ambient / supply (°C)						
	-15	-10	-5	0	+5	+10	+15
1	1.54	1.33	1.15	1.0	0.87	0.75	0.65
2	2.0	1.59	1.26	1.0	0.79	0.63	0.50
3	2.46	1.88	1.37	1.0	0.75	0.53	0.41
4-8	2.71	1.95	1.4	1.0	0.71	0.51	0.37

Plenum box spigot volumes (l/s)

Diameter mm	Spigot velocity m/s					
	1.5	2.0	2.5	3.0	3.5	4.0
100	10	15	19	22	26	30
125	18	24	30	35	41	47
150	25	34	42	51	60	68
175	35	46	58	70	82	94
200	45	60	75	91	109	121
225	58	77	96	117	137	151
250	71	95	120	142	170	191
275	86	115	145	172	205	230
300	103	139	172	208	240	275
325	120	160	200	240	280	320
350	140	188	235	280	328	375
400	185	245	310	370	430	495

Method Plenum Boxes

1. Determined volume of plenum box by multiply chosen length of box x volume/metre of slot. (A maximum box size of 2.0m long is recommended). Plenum boxes in excess of 1500mm long require 2 or more inlet spigots.

2. Select plenum spigot size from table. Maximum entry velocity of 3.5 m/sec is recommended. Velocities in excess of this may lead to noise generation.

3. From table of 'Plenum Box Pressure Drops and Sound Ratings' read off additional pressure drop to be added to slot diffuser pressure drop from graph. Ensure that plenum box sound power level is not more than slot diffuser reading if latter is design criteria.

4. Where it is not possible to accommodate standard plenum boxes, special configurations are available, but should always maintain an equivalent cross-sectional area to a standard box. Consideration should also be given to the inlet spigot in respect of positioning, sizing and inlet velocities. Consult our technical department for detailed advice



EMINT

Kanat Pozisyonuna Göre Hava Akışı

Supply

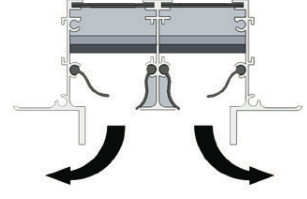
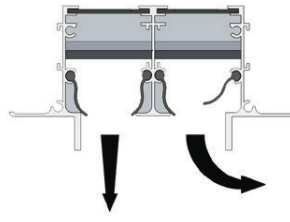
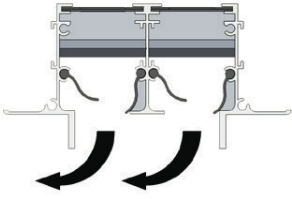
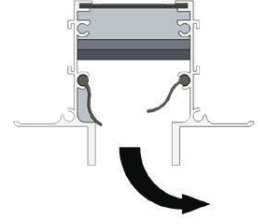
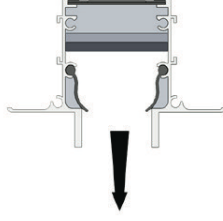
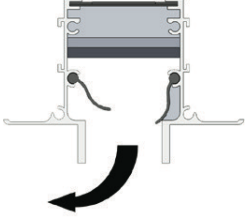

Return

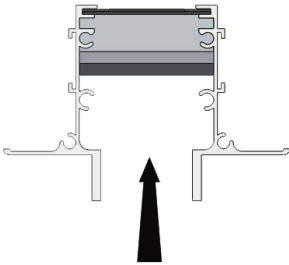



gerhman.com



• +90 0850 303 47 66 (GRMN)



• info@gerhman.com



• gerhman.com