



Linear Grilles

Linea

At Gerhman we are driven by a strong desire to continuously generate improvements. We do that by developing products and systems that are easy to use and energy efficient, together with industry-leading knowledge, support, logistics and efficient availability.



gerhman.com

Linear Grilles

Linea



LINEA Linear grilles are mostly preferred products that are used in heating, cooling and ventilation systems because of their aesthetic appearance. They can be used as supply or exhaust grilles on air ducts in large spaces for heating and cooling. Besides, they are the mostly preferred products on and next to fan coils and radiators. The distance between the blades and the thickness of the profile that is used on blades provides a durable structure and the aesthetic appearance ensures ideal ventilation equipment. For the spaces when linear appearance is required, many grilles can be combined and long grilles can be formed as needed.

Properties

- They are used as supply and exhaust grilles on air ducts. *They can be manufactured with large and narrow cases. *Can be manufactured with or without frames.
- Extruded aluminum profile is used.
- Blades are produced as 0° or 15° angle according to product type.
- They can be manufactured as anodized or with electrostatic powder coating (colors from RAL catalogue can be chosen).
- To adjust the blowing air damper can be added. Also, dampers can be manufactured with parallel or opposite blades.

* No	Model	Application
1	Linea S100	0° Angle Blade Standard Linear Grille For Wall and Ceiling
2	Linea S115	15° Angle Blade Standard Linear Grille For Wall and Ceiling
3	Linea S300	0° Angle Blade Standard Linear Grille For Floor, Wall and Ceiling
4	Linea S315	15° Angle Blade Standard Linear Grille For Floor, Wall and Ceiling
5	Linea S400	0° Angle Blade Special Floor Type Linear Grille for Data and System Room
6	Linea S415	15° Angle Blade Special Floor Type Linear Grille for Data and System Room

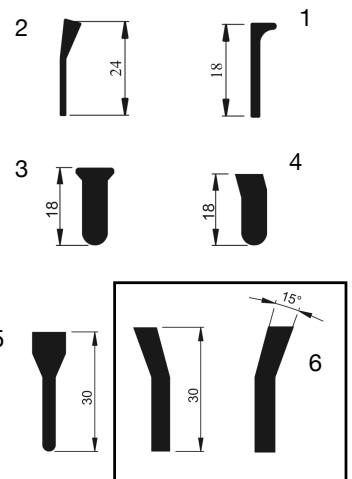

* Specially designed blades according to product type

Linear Grilles

Linea

Standard Sizes

Each grille is named by W*H

W	300	500	500	750	750	1000	1000	1000	1000
H	75	75	150	150	250	150	250	300	500

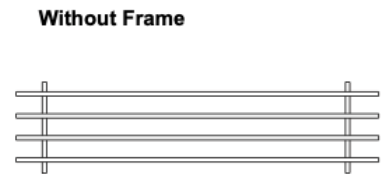
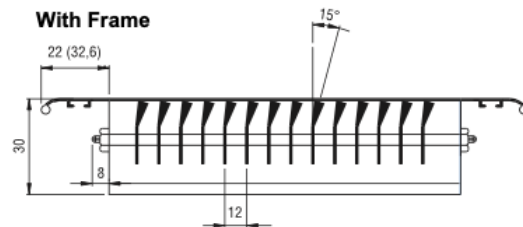

Installation

Screw system is the standard mounting type, however according to the application place, there are different mounting types as; Clip system and Plate spring system.

Screw Mounting

It is the standard mounting type and with the holes on the frame for Ø4mm they can be installed. They can be used without screws on radiators.

Plate Spring System

They are good solutions for deep surfaces. This type of mounting is done by steel plates on the side surfaces of the grilles case. They can be used with or without case.

Installation with Clip System

They can be applied with blind case. Blind case is mounted to mounting holes. For mounting, clip mounted on the grille and by the help of screwdriver clip installed to the blind casing

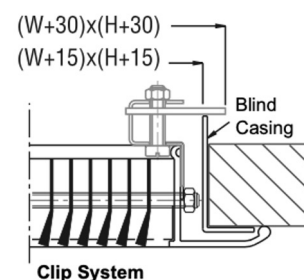
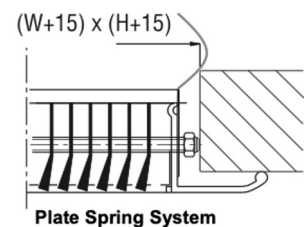
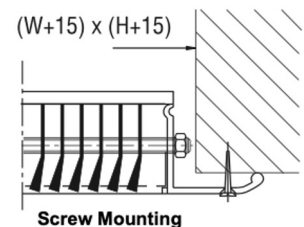

Plaster-in Linear Grilles

Linea S100 / S300 (+ZC)



[gerhman.com](https://www.gerhman.com)

Framless Linear Grilles

Linea S100 / S300 (+ZC)

Linea S100+ZC

Clips (Plate Spring Fixing)

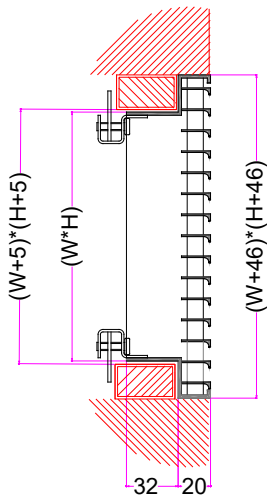

Screw Fixing

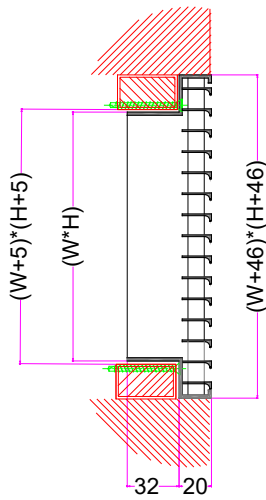

Without Neck

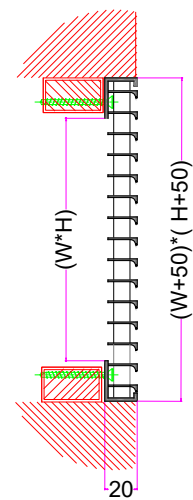

Linea S300+ZC

Clips (Plate Spring Fixing)

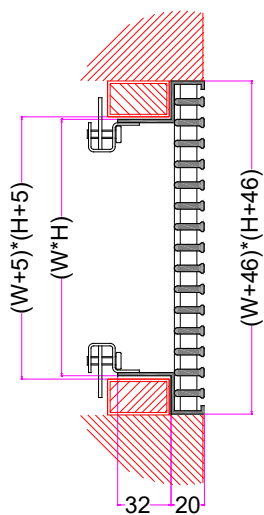

Screw Fixing

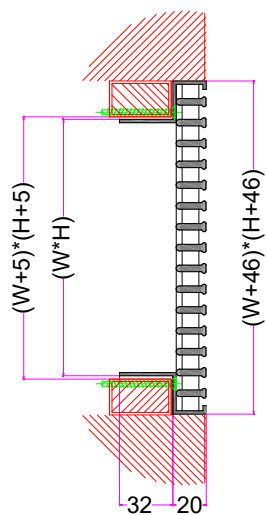

Without Neck

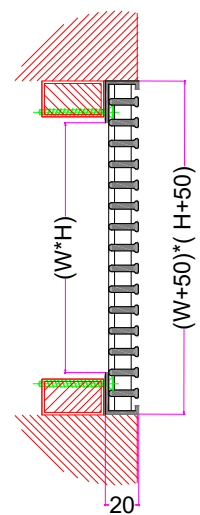

Plaster-in Linear Grilles

Linea (+PG)

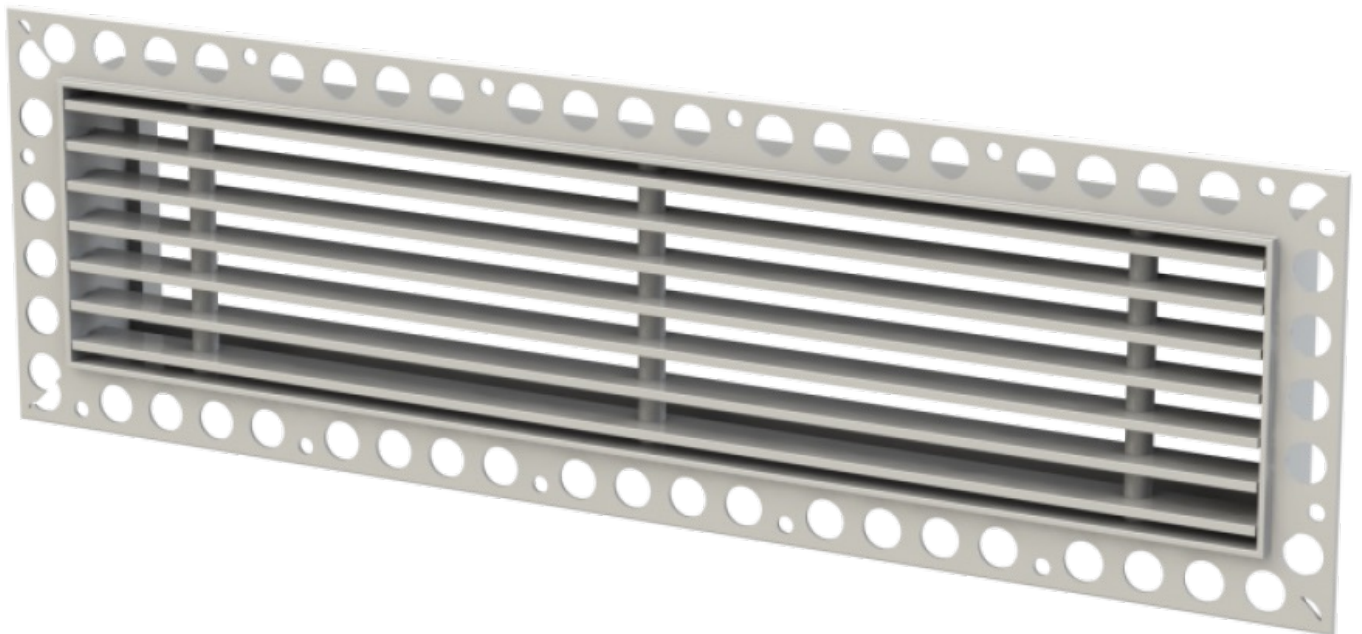

gerhman.com

General Information

Linea (+PG)

Linear Grilles

Linea

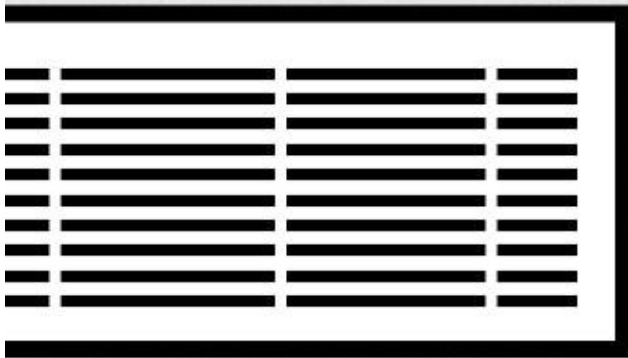

Plaster-in Linear Grilles

Linea (+PG)

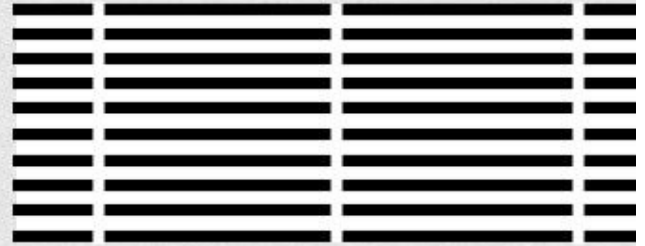

X

Looking for a cleaner, more streamlined grille construction in your project?

Linea+PG grilles might be the ideal solution for you. The flush finish provided by this implementation leaves your walls looking pristine, while still allowing for incredible airflow and efficiency. It transforms your linear bar grilles from a standard, low-budget look into a timeless (and seamless) integration with the rest of the room.

Some of the great features that put our +PG grilles above the rest:

- Borderless installation, even on curved surfaces.
- Achieve a Level 5 plaster finish.
- Pre-punched holes for quick mounting. Add plaster and smooth it out!
- Aluminum, bronze or stainless steel options.

Plaster-in Linear Grilles

Linea (+PG)

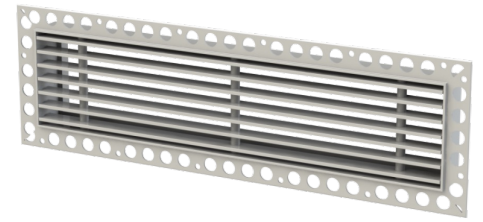

New frame for linear bar grilles which is designed to be plastered in giving a seamless appearance once installed. New plaster-in frame uses or ordering additional code '+PG'. **Linea+PG** have been designed to satisfy air diffusion and engineering requirements while providing a narrow plaster-in border to meet architectural specifications. Plasterline grilles may be used in modular or continuous situations for sidewall, cill or bulkhead applications. The range is available with a wide variety of special options and fabrications to suit most project requirements. All applications can be achieved with the use of a standard fixed core version.

Description

*New frame for linear bar grilles which is designed to be plastered in giving seamless appearance once installed.

*The front border is designed to integrate seamlessly within plasterboard builders work opening, with a concealed screw fix installation.

*Blades are produced as 0° or 15° angle according to product type.

*They can be manufactured as anodized or with electrostatic powder coating (colors from RAL catalogue can be chosen).

- *To adjust the blowing air damper can be added. Also, dampers can be manufactured with parallel or opposite blades.

* No	Model	Application
1	Linea+PG S100	0° Angle Blade Standard Linear Grille For Wall and Ceiling
2	Linea+PG S115	15° Angle Blade Standard Linear Grille For Wall and Ceiling

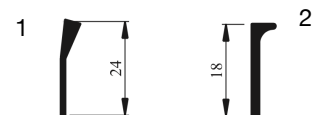

* Specially designed blades according to product type.

General Information

Linea (+PG)

Sizes

Single Module

W = 150 - 2400 mm

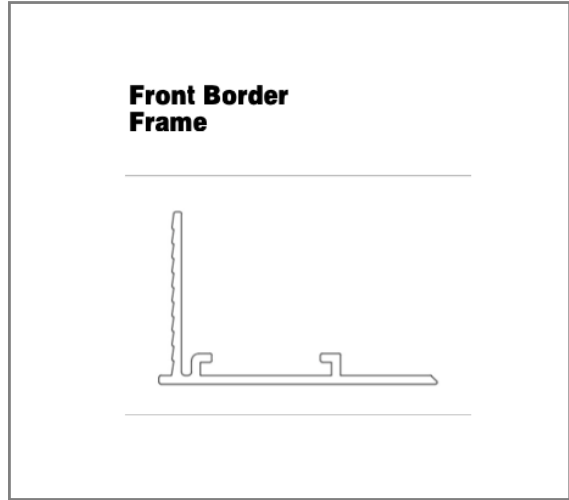
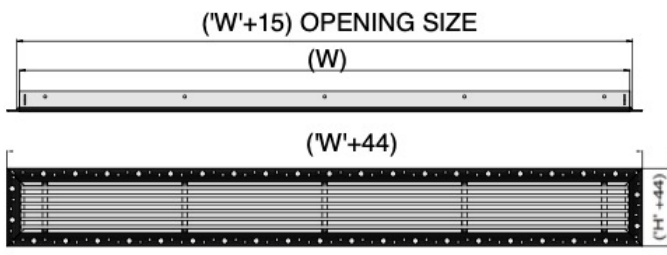

Nominal Height For Single and Multi Module

H Min= 50 mm H Max = 800 mm

Multi Module

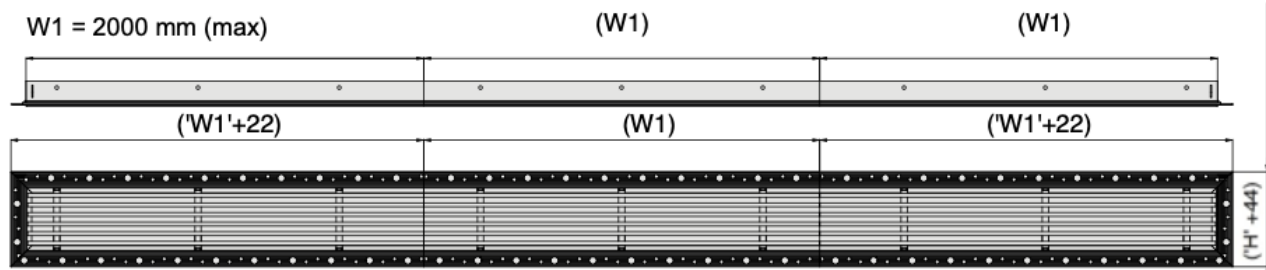

W	300	500	500	750	750	1000	1000	1000	1000
H	75	75	150	150	250	150	250	300	500

Linear Grilles

Linea



gerhman.com

Selection Graph

Linea / Linea+PG S115

15° Angle Blade Standard Linear Grille For Wall and Ceiling

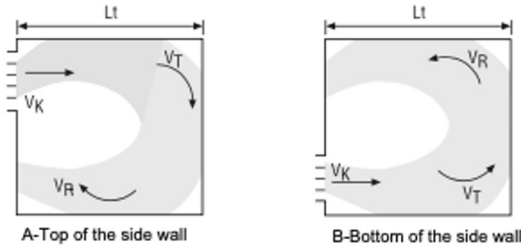

S115

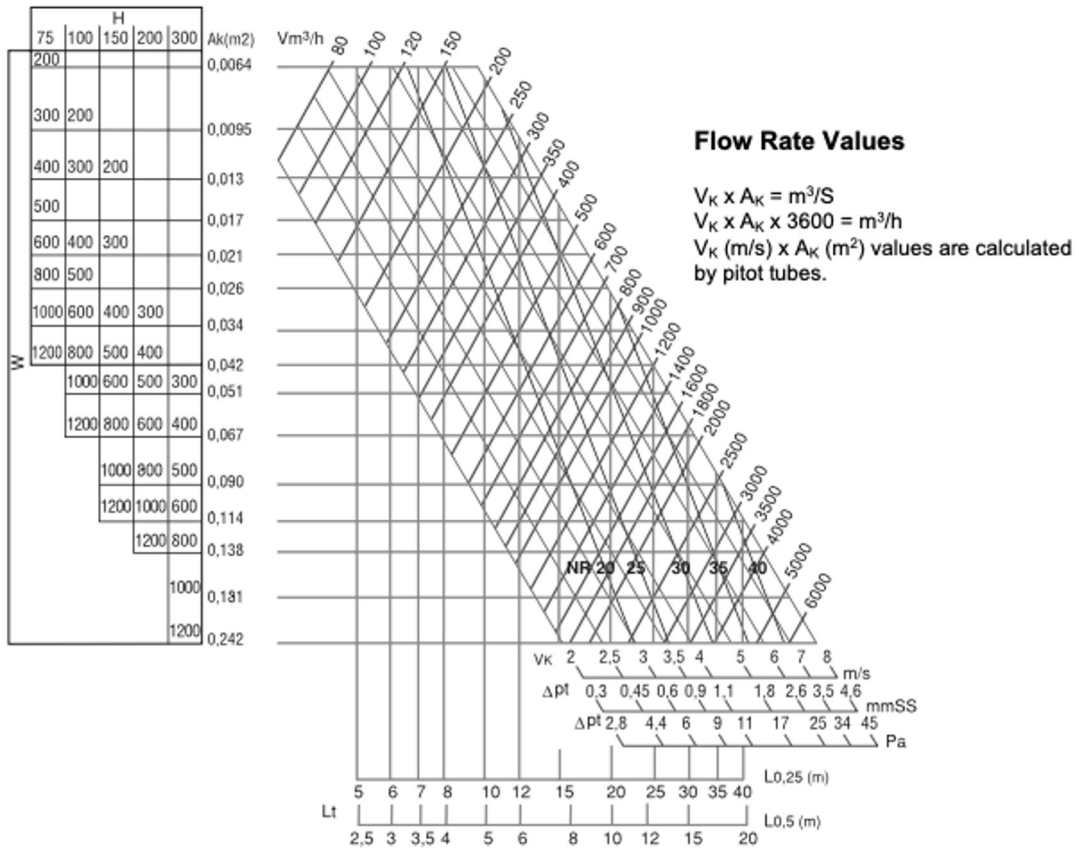

Correction Factor V_T

V_T (m/s)	0,25	0,375	0,5	0,625
A	x1	x0,67	x0,5	x0,4
B	x0,7	x0,47	x0,35	x0,28

Selection Graph

Linea / Linea+PG S100

0° Angle Blade Standard Linear Grille For Wall and Ceiling

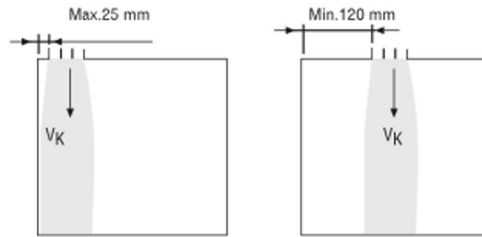

All datas in the selection graph had given for 1m length

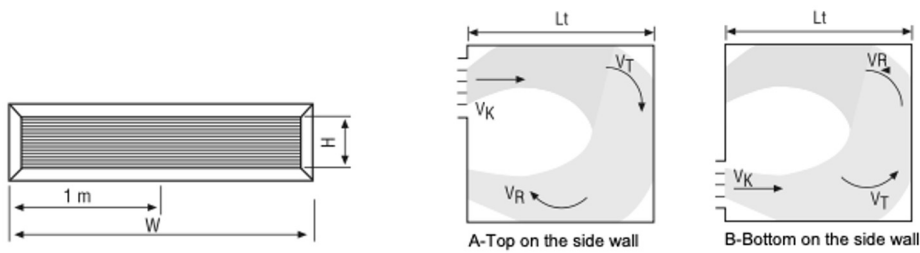

S100

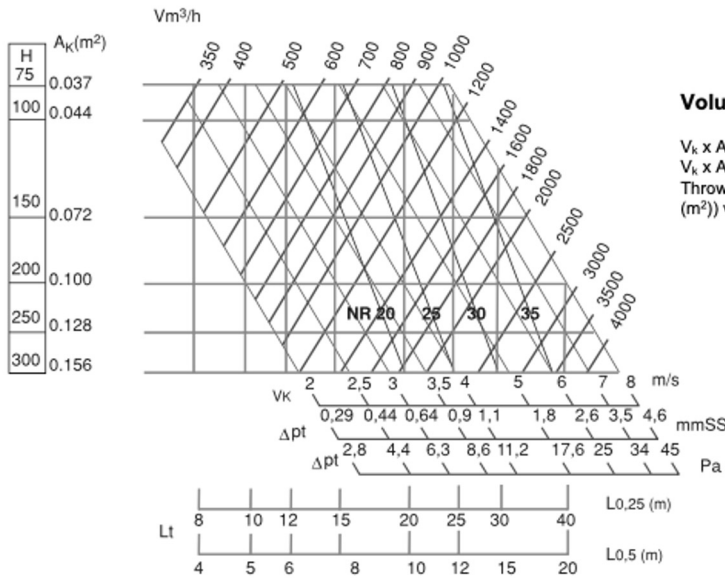

Volume Flow Rate Calculation

$V_k \times A_k = m^3/s$
 $V_k \times A_k \times 3600 = m^3/h$
 Throwing velocity (V_k) and A_k (Effective Area (m^2)) values are measured with pitot tubes.

For Correction Factor W

W (m)	1	1,5	2	2,5	3	4	5	6	8	10
Lt (m)	x1	x1,05			x1,1				x1,15	
NR	0	+2	+3	+4	+5	+6	+7	+8	+9	+10

Correction Factor V_T

V _T (m/s)	0,25	0,375	0,5	0,625	
Lt	A	x1	x0,67	x0,5	x0,4
	B	x0,7	x0,47	x0,35	x0,28

Floor Linear Grilles

Linea S300, S315, S400, S415

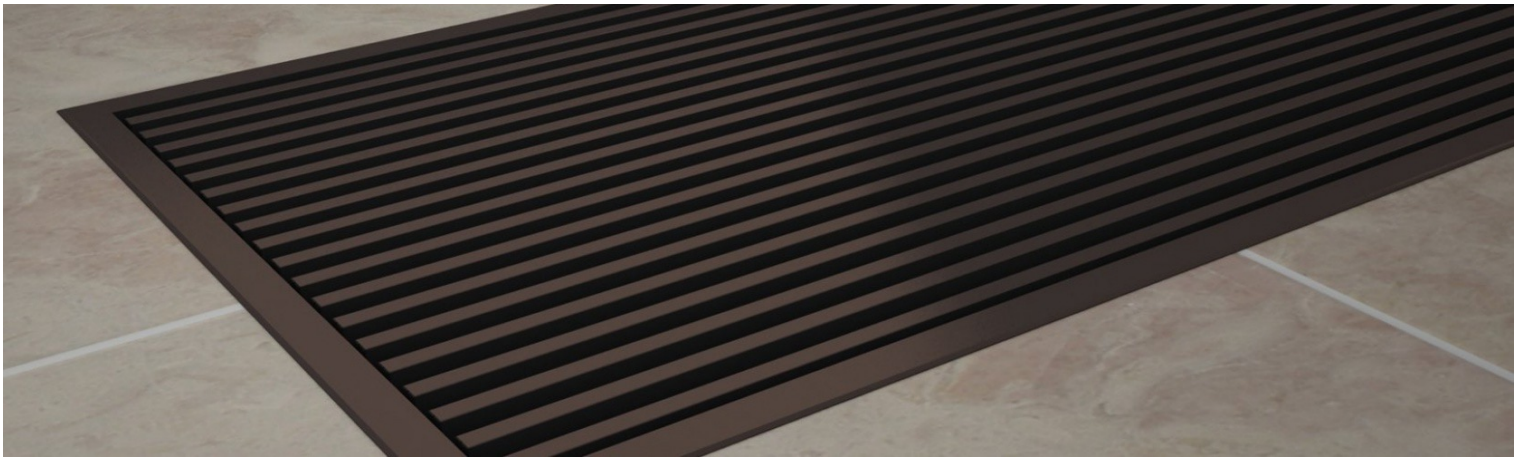

gerhman.com

Floor Linear Grilles

Linea S300, S315

These types of grilles are used for every purposes which needs decorative conditions. S300 and S315 type linear grilles, are also named as floor grilles. S300 type linear grilles, have the same properties with S315. The only difference is they have 15° blade angle. They can be also used for walls and ceilings.

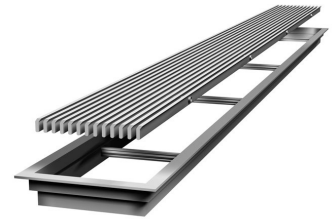

Blade Types

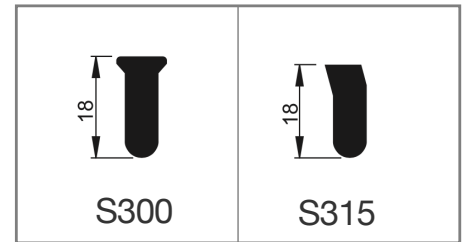

Standard Sizes

Each grille is named by W*H

W	300	500	500	750	750	1000	1000	1000	1000
H	75	75	150	150	250	150	250	300	500

Floor Installation

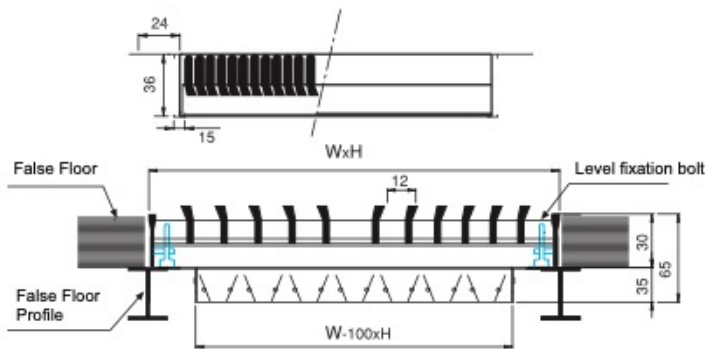

Wall, Ceiling Installation

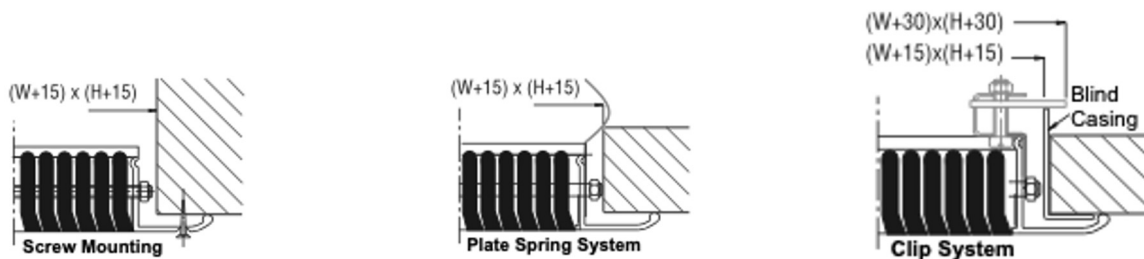

Selection Graph

Linea S300

0° Angle Blade Standard Linear Grille For Wall and Ceiling

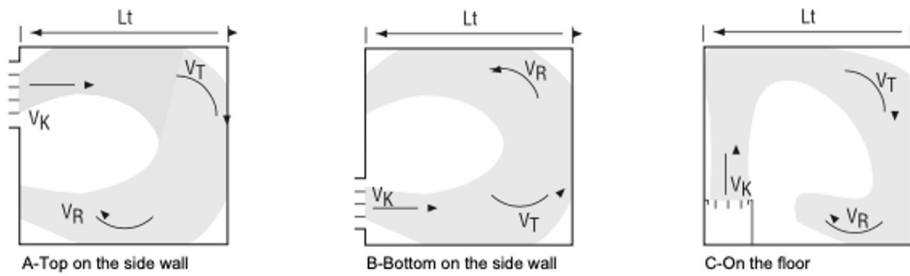

S300

H	LM200		LM200-300-400				LM200	
	50	63	75	100	150	200	300	400
400			200					
500			300	200				
600	400							
800	500		400	300	200			
1000	600		500					
1200	800		600	400	300	200		
1000	800		500					
	1200		1000	600	400	300		
1200	1000		1200	800	500	400		
	1200		1000	600	500	300		
			1200	800	600	400		
			1000	800	500	400		
			1200	1000	600	500		
			1200	800	600			
				1000	800			
				1200	1000			
								1200

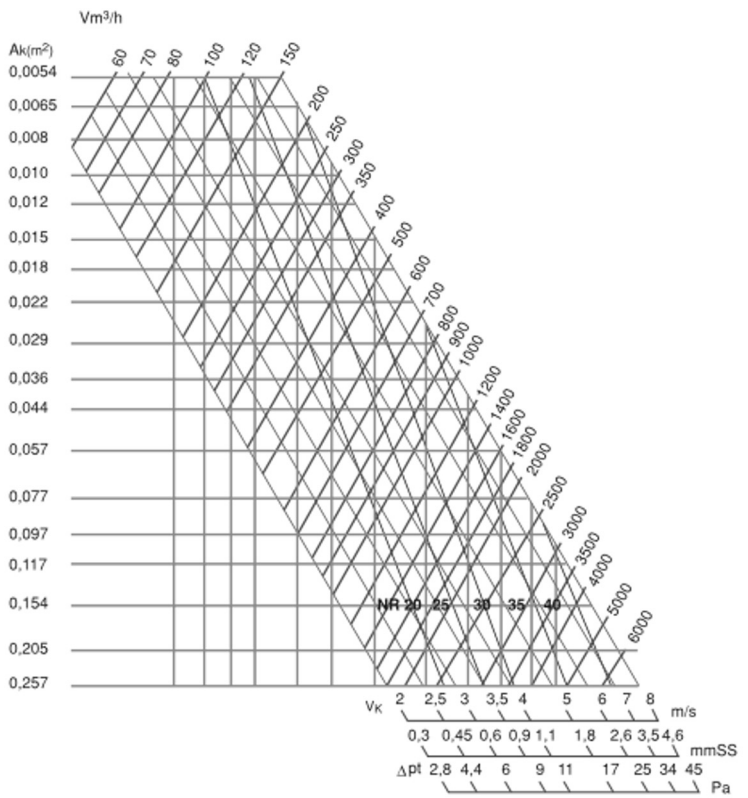

Correction Factor V_T

V_T (m/s)	0.25	0.375	0.5	0.625	
L_t	A	x1	x0,67	x0,5	x0,4
	B	x0,7	x0,47	x0,35	x0,28

Selection Graph

Linea S315

15° Angle Blade Standard Linear Grille For Wall and Ceiling

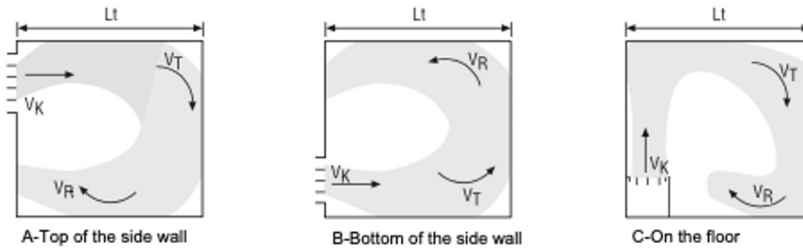

S315

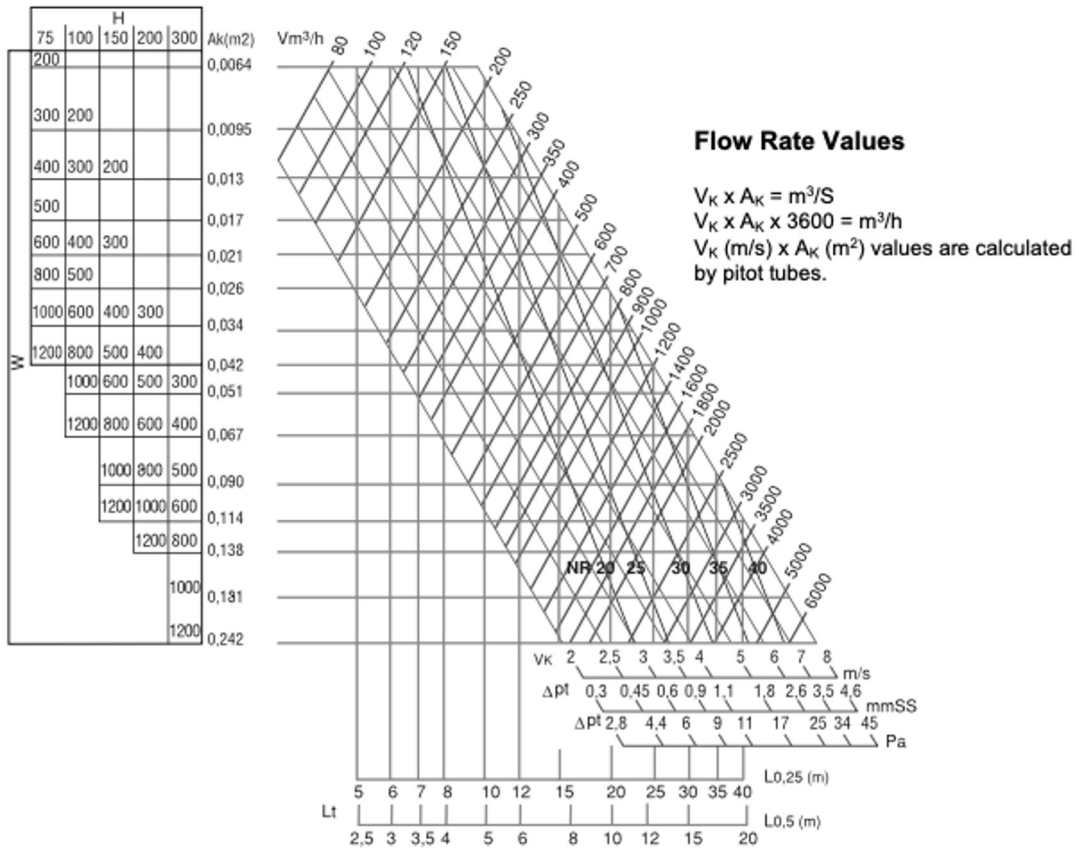

Floor Linear Grilles

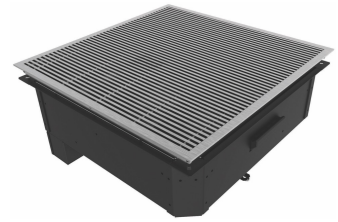

Linea S400 S415

FOR DATA AND SYSTEM ROOMS. They are used in places with acclimatization's from floor. This type of mounting is done by steel plates on the side surfaces of the grilles case. The damper that is used to adjust air flow can be controlled easily from the top. According to the order, dampers can be parallel with the long or the short corner. If requested, dust holding filter can be added.

S400 type linear grilles; they are also named as floor grilles. S415 type linear grilles; has the same properties with S400. The only difference is they have 15° blade angle.

Standard Sizes

Each grille is named by W*H

W	600	600	600
H	100	150	200

Blade Types

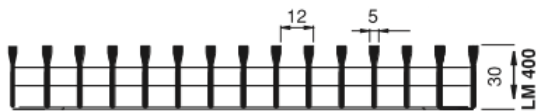
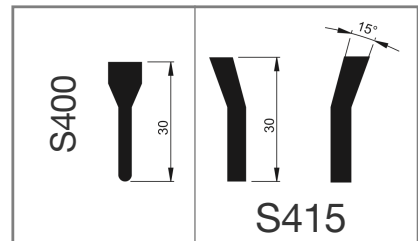

S400



S415



Installation

Linea S400 S415

False Floor Frameless Type Linear Grille With Damper

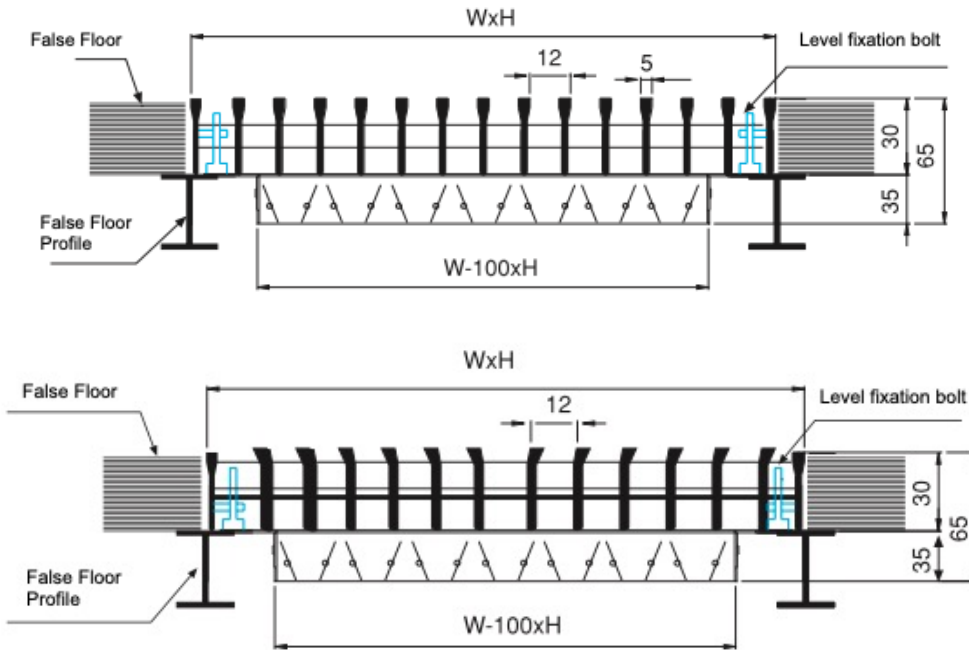

False Floor Framed Type Linear Grille With Damper

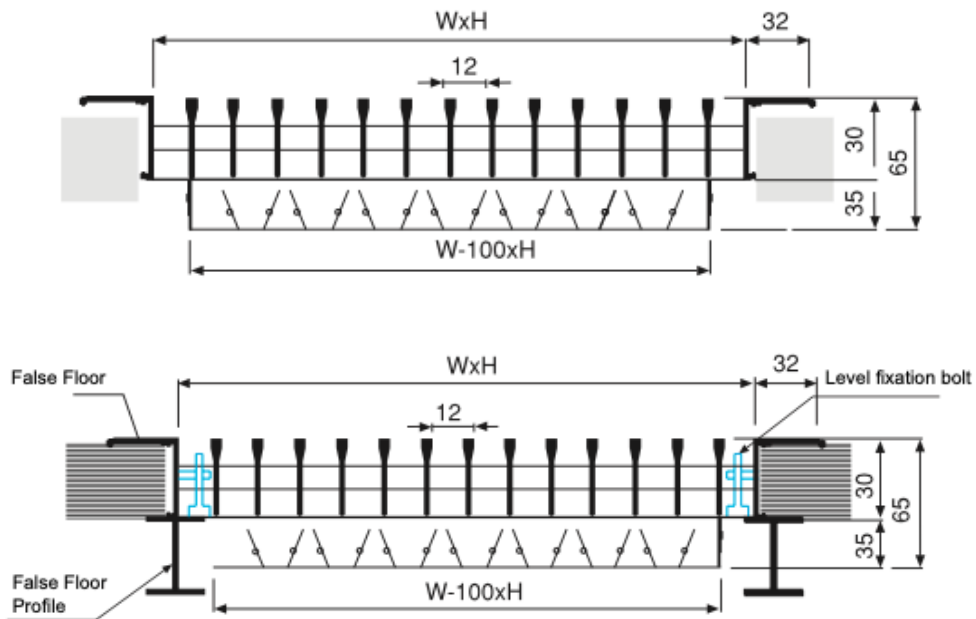

Installation

Linea S400, S415

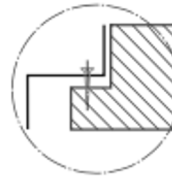
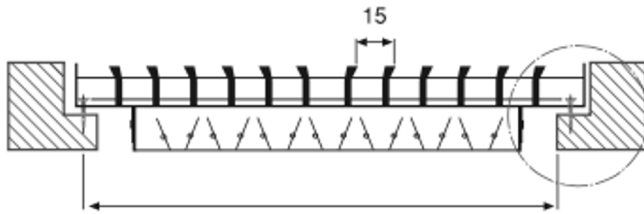

Frameless Type Mounting

Linear grilles that are manufactured without frames are fit into special blind cases. After that blind cases are fixed with screws.

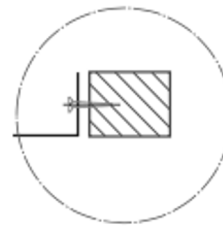
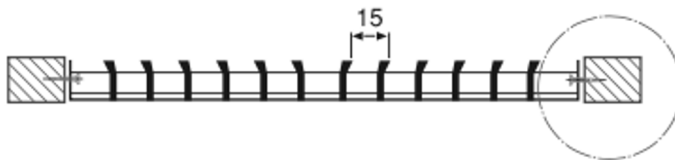

Linear Grille with Access Door

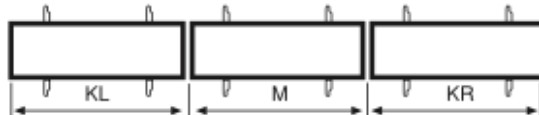
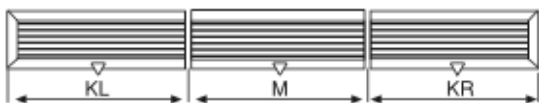

Serial Mounting

For the linear grilles that are added together are mounted serially. The images in the connections are reduced to minimum level and a good appearance is obtained.

Also, 90° and 135° angled corner linear grilles are used for connection.

KL- Left Corner
M - Middle
KR- Right Corner

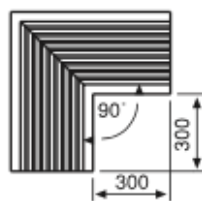

Corner Grille

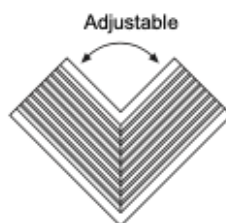

Corner Grille

They are used for connections at ceilings, floor applications and wall joints. There are no dampers at corners and they can be manufactured with the requested angles.

Accessories

Linea S400, S415

False Floor Linear Grille With Damper and Dust Collecting Casing

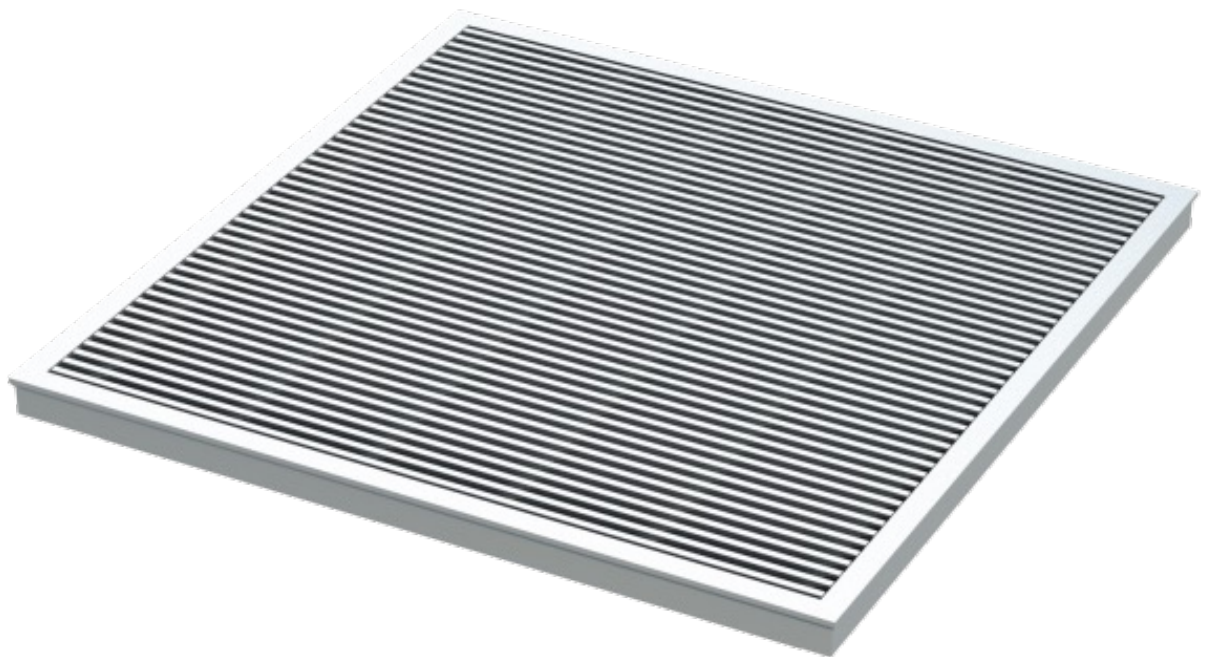
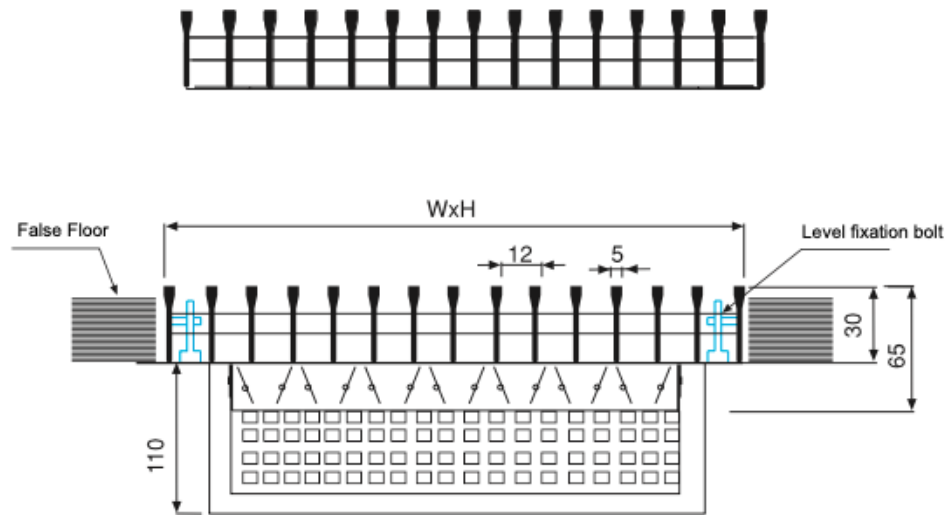

Selection Graph

Linea S400

0° Angle Blade Standard Linear Grille For Wall and Ceiling

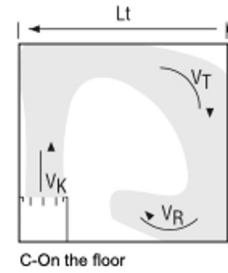

S400

W	LM200		LM200-300-400				LM200	
	H		H					
400	50	63	75	100	150	200	300	400
500			200					
600	400							
800	500		300	200				
1000	600		400	300	200			
1200	800		600	400	300	200		
	1000		800	500				
	1200		1000	600	400	300		
			1200	800	500	400		
				1000	600	500	400	
				1200	800	600	500	
					1200	800	600	
						1000	800	
						1200	1000	
							1200	

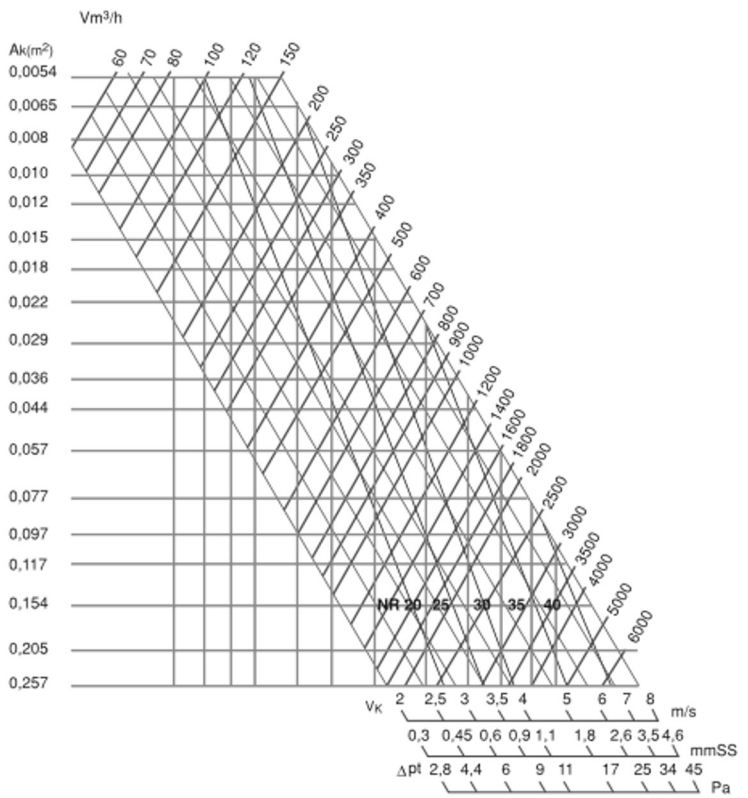

Correction Factor V_T

V _T (m/s)	0,25	0,375	0,5	0,625
L _t	A	x1	x0,67	x0,5
	B	x0,7	x0,47	x0,35

Selection Graph

Linea S415

15° Angle Blade Standard Linear Grille For Wall and Ceiling

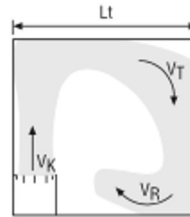

C-On the floor

S415

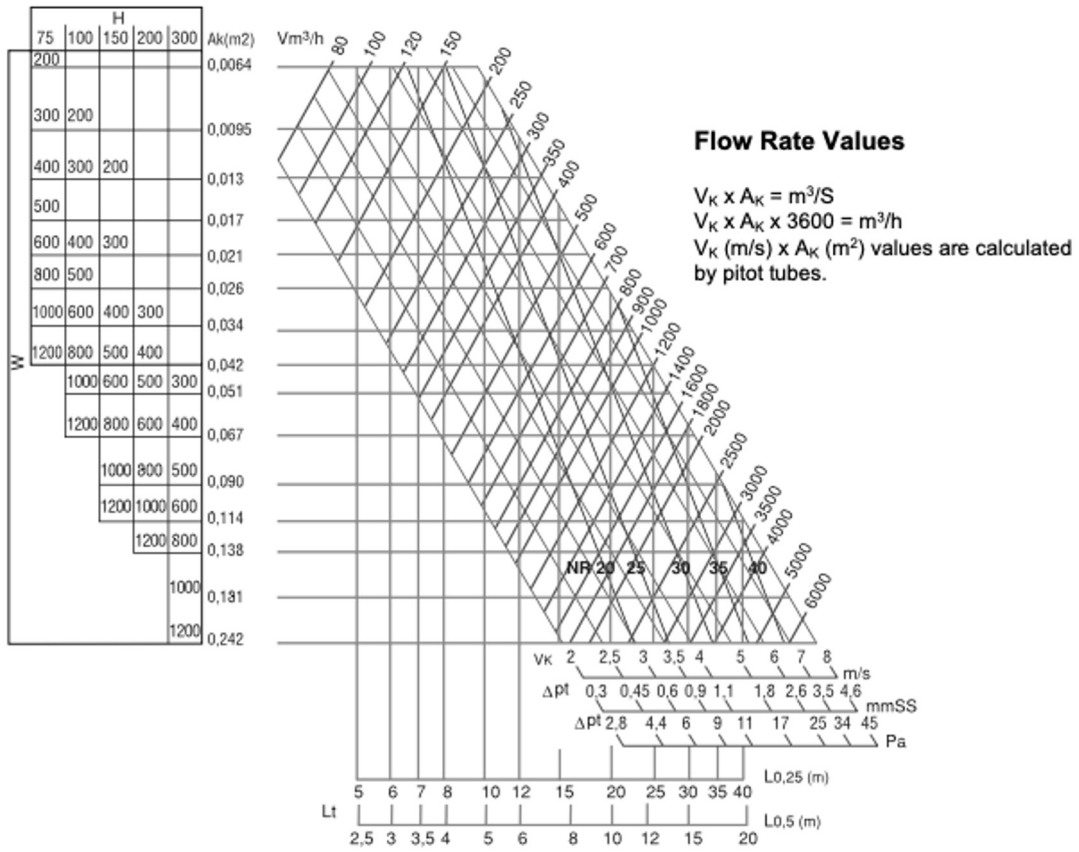

Flow Rate Values

$V_K \times A_K = m^3/S$
 $V_K \times A_K \times 3600 = m^3/h$
 $V_K (m/s) \times A_K (m^2)$ values are calculated by pitot tubes.

Correction Factor V_T

$V_T(m/s)$	0,25	0,375	0,5	0,625	
L_t	A	x1	x0,67	x0,5	x0,4
	B	x0,7	x0,47	x0,35	x0,28

Accessories

Linea

OD calibration damper
 OD calibration damper with fins with opposing movement



Installation sub frame



Plenum box

- Can be used for both supply and extract air
- Easy-to-detach the grilles for access to the plenum
- Same box used for several type of grilles
- Special lip bend allow an easy clips mounting of all grilles model

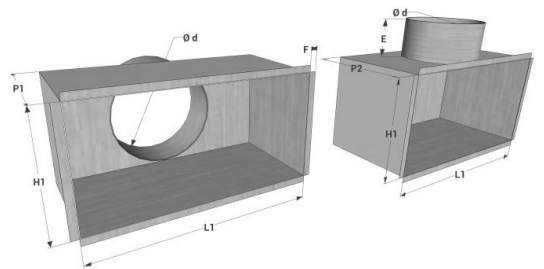

All dimensions are expressed in mm.

model L1 x H1	upper air connection			side air connection			E	F	model L1 x H1	upper air connection			side air connection			E	F
	P1	n° connection	Ø d	P2	n° connection	Ø d				P1	n° connection	Ø d	P2	n° connection	Ø d		
200x100	200	1	98	200	1	98	80	12	1000x200	200	2	198	300	2	198	80	12
300x100	200	1	98	200	1	98	80	12	300x300	200	1	248	350	1	248	80	12
400x100	200	2	98	200	2	98	80	12	400x300	200	1	248	350	1	248	80	12
500x100	200	2	98	200	2	98	80	12	500x300	200	1	248	350	1	248	80	12
600x100	200	2	98	200	2	98	80	12	600x300	200	2	198	350	2	248	80	12
800x100	200	2	98	200	2	98	80	12	800x300	200	2	248	350	2	248	80	12
200x200	200	1	198	300	1	198	80	12	1000x300	200	2	248	350	2	248	80	12
300x200	200	1	198	300	1	198	80	12	400x400	200	1	298	350	1	298	80	12
400x200	200	1	198	300	1	198	80	12	500x400	200	1	298	350	1	298	80	12
500x200	200	1	198	300	1	198	80	12	600x400	200	2	198	350	2	248	80	12
600x200	200	2	198	300	2	198	80	12	800x400	200	2	298	350	2	298	80	12
800x200	200	2	198	300	2	198	80	12	1000x400	200	2	298	400	2	298	80	12
560x560	-	-	-	300	1	248	80	12									

SELECTION GUIDE

Spigot Velocity (m/s)	1,5	2	2,5	3	3,5	4	4,5	5	6		
Pressure Drop (Pa)	2	4	6	8	12	16	20	28	36		

*The pressure drop given is for supply diffuser with damper fully open.
 When the diffuser is installed with plenum box the pressure loss of the box has to be added to the diffuser.

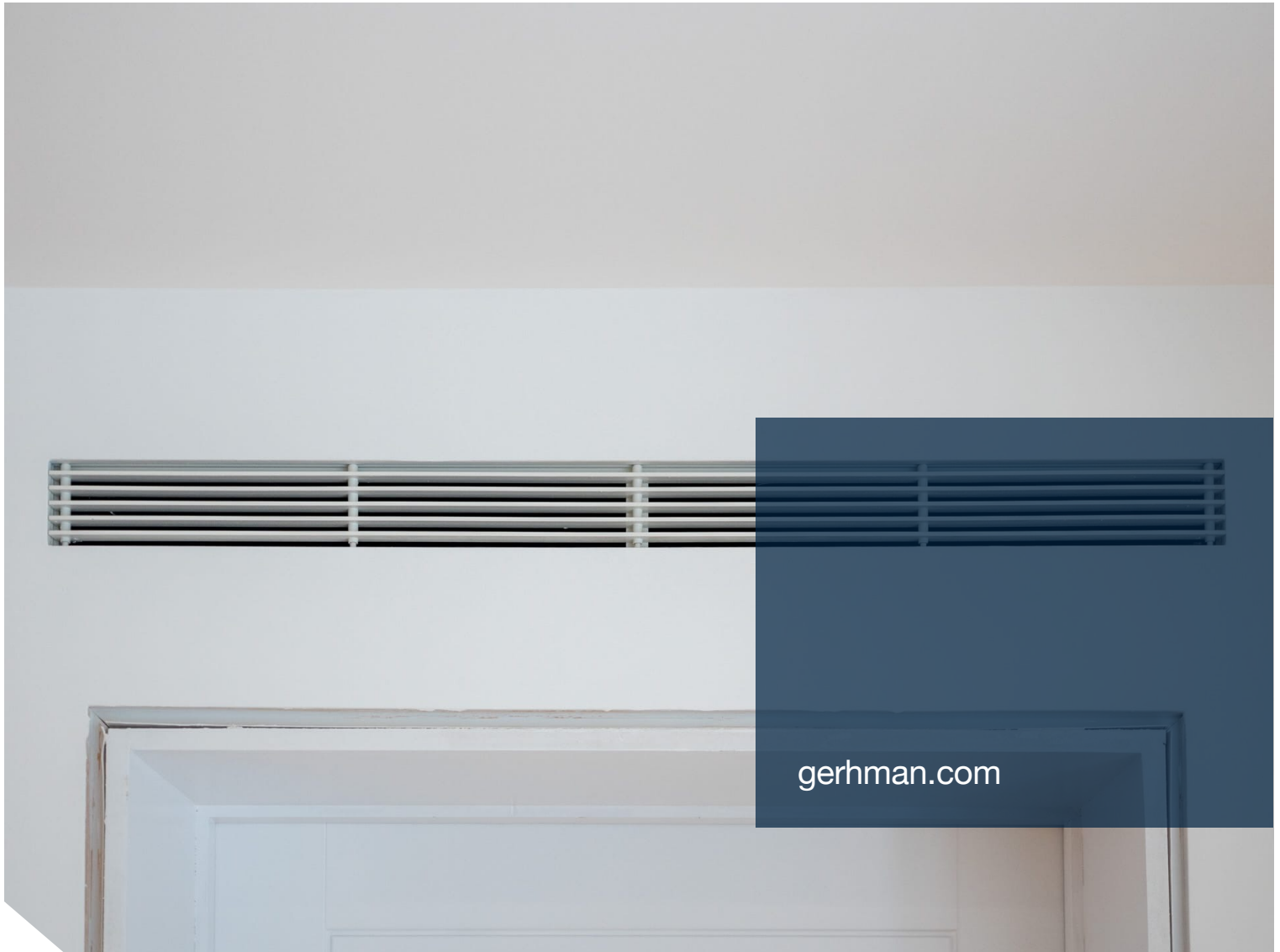

gerhman.com

Linear Grilles

Linea



• +90 0850 303 4766



• info@gerhman.com



• gerhman.com